

# Creative Workshops

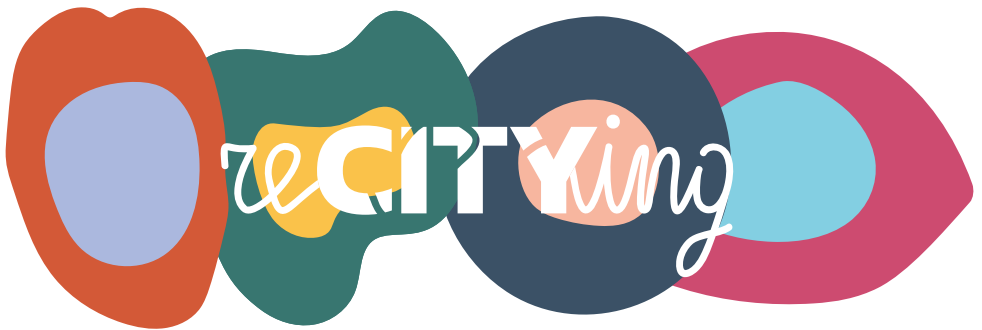

**reCITYing**  
**Creative Workshops**  
**Creative Europe Programme**  
**(CREA-CULT-2023-COOP)**

**2024-2028 cofunded by the European Union**

Partners:

Genoa Unige Università di Genova  
 Barcelona Iaac Institute of Advanced Architecture of Catalonia  
 Hannover LUH Leibniz Universität Hannover  
 Maribor Umetnostna galerija Maribor  
 Montpellier, Association Champ Libre

## Creative Workshops

### *Work Package 3*

The Genoa Workshop (June 17-19, 2024) transformed the historic Albergo dei Poveri into a creative laboratory. Participants developed 19 place-based installations for the building's courtyards, with prototypes evaluated by an international jury. The program included expert dialogues, guided tours, and collaborative performances, culminating in project selection for installation in 2025.

The Barcelona Workshop (October 9-11, 2024) at the Institute for Advanced Architecture of Catalonia focused on agricultural spaces at Parc Agrari del Baix Llobregat. Participants explored circular economy principles, transforming agricultural by-products into zero-waste architectural installations. The workshop featured hands-on activities including co-planting materials for future installations and community engagement through local sustainable food experiences.

The Hannover Workshop (December 4-6, 2024) at Leibniz University centered on music and urban design at Lindener Hafen. Participants developed acoustic-inspired installations reflecting the area's unique soundscapes, emphasizing sustainability and material innovation through immersive exploration and creative mockup development.

The Maribor Workshop (March 26-28, 2025) at UGM Maribor Art Gallery addressed the reactivation of the historic Račji dvor Mansion through visual arts. Following an open call for interventions, the workshop combined expert lectures on revitalization projects with site visits and proposal presentations, fostering interdisciplinary approaches to heritage conservation and urban regeneration through creative collaboration.





**Genoa  
Workshop  
17-19.06.2024**

**Albergo  
dei Poveri**

**reCITYing**  
**Genoa Workshop**  
**Creative Europe Programme**  
**(CREA-CULT-2023-COOP)**

**2024-2028 cofunded by the European Union**

Partner:

Genoa Unige Università di Genova

Barcelona Iaac Institute of Advanced Architecture of Catalonia

Hannover LUH Leibniz Universität Hannover

Maribor Umetnostna galerija Maribor

Montpellier, Association Champ Libre



**reactivating unused urban spaces  
 through architecture and arts**

## Genoa Workshop

The Albergo dei Poveri opens its doors for the Creative Workshop of the ReCITYing project to be held from 17 to 19 June 2024 in Genoa. The courtyard will become the stage for 19 place-based proof of concepts created by students and creatives for performative space installations. The possibility of interacting with the body of the sleeping giant by staging prototypes or parts of the installations will be an opportunity to activate a direct exchange between young creatives and partners in a creative co-creation open lab. An exhibition will be set up along the corridor connected to the courtyard to show the project work through posters, booklets and studio models. Thanks to the presence of an international jury of experts and a local company of arts, the exhibited works will be evaluated in order to realise the Space Installations in 1:1 scale in the next phase. The first day of the Workshop will be animated by the Re-talks dialogues where a first phase of reports from partner cities will be followed by a series of interventions by Carlo Sciaccaluga, Lisetta Buccellato and Marc Aureli Santos to conclude with a round table among the participants. Opening the second day will be the ReCITYing meeting followed by the Albergo dei Poveri guided tour of courtyards, inner church, venue of ReCITYing Installation 2025. The afternoon activity will be the Performative parts with creative event: after an initial phase of Collaborative touch-ups and Proof-of Concepts finalization there will be the presentation of prototypes and performances by Unige and Accademia Students with the participation of ReCITYing partners, Unige Tutors, creatives, artists and local stakeholders. The morning of the third day will be dedicated to the selection of project for the Installation and an award ceremony.



## Venue:

**Albergo dei Poveri, Genoa**  
Piazzale Emanuele Brignole, 2

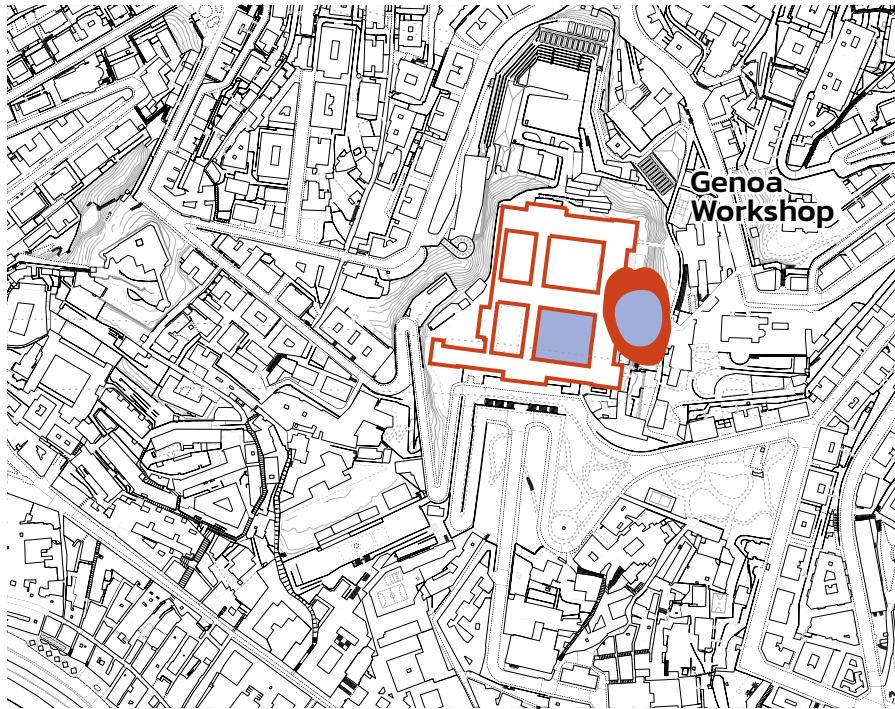

## Preliminary Activity

13-14 June 2024

UniGe - 9:00-19:00

**Department Architecture and Design**

Stradone S. Agostino, 37

room 5B/5C proof-of-concepts &  
prototypes preparation, panels, booklets

## 17 June 2024

9:30-13:00

room 8 \_ ReCITYing speed date:  
project inputs and interactions

13:00-16:00

room 8 \_ UniGe + Accademia students  
1 manifesto based on opera libretto  
courtyard \_ UniGe students  
exhibition construction + scenography

16:00-19:00

**Aula Magna**

**Re-Talks  
dialogues**

**Welcome**

Nicolò Casiddu, Direttore DAD

16:00-16:20

**ReCITYing project:**

**Albergo dei Poveri as a stage**

Manuel Gausa, Emanuele Sommariva

16:20-17:00

**ReCITYing project:**

**report from partner cities:**

Barcelona, Hannover, Maribor

17:00-17:30

**Carlo Sciaccaluga**

Stage direction and scenic design

17:30-18:00

**Lisetta Buccellato, Paris**

The scenic design from conception to the stage

18:00-18:45

**Marc Aureli Santos, Barcelona**

Barcellona \_ the creative factories

18:45-19:15

**Round Table & Discussion**

Chair: Silvia Pericu

Discussants: Nicola Canessa, Chiara Olivastri

# 18 June 2024

09:30-11:30  
*ReCITYing meeting: partners think-tank*  
room E, left entrance ground floor

11:30-13:00  
*Albergo dei Poveri guided tour \_  
abandoned spaces & reactivation \_*  
Arch. M. Sinesi / A. De Marini  
Tour of courtyards, inner church, venue  
of ReCITYing Installation 2025  
*only for reCITYing partners*

9:30-16:00  
*Collaborative touch-ups:  
Proof-of Concepts finalization*  
Exhibition SET-UP at Courtyard +  
Long corridor, 2° floor

room 2 \_ UniGE + Accademia students  
finalize manifesto based on opera libretto

long corridor \_ UniGE students exhibition  
wall set-up (A1 Panel,model + book)

courtyard \_ UniGe students finalize  
prototypes

16:00-18:00  
***Performative  
parts: creative  
event***

**courtyard**

**UniGe + Accademia Students  
presentation of prototypes  
and their performances**  
curated by Giorgia Tucci

participants:  
ReCITYing partners +  
Unige Tutors +  
creatives, artists, local stakeholders

# 19 June 2024

9:00-13:00  
***ReCITYing  
Workshop  
International  
Jury***

**long corridor**  
UniGe students short presentation  
(5' min) + critical  
12+12 proof-of-concept exhibition on  
the long wall + manifestos + booklet

**room 3**  
***cerimony award*** + selection of project  
for the Installation

**Website:  
[www.recitying.org](http://www.recitying.org)  
Follow us  
on Instagram**



## ReCITYing paradigms: a matter of places, players and cultures

Manuel Guasa, Emanuele Sommariva

Recycling means putting things back into circulation, reusing waste materials that have lost their value and/or meaning. It is a practice that makes it possible to reduce waste, to generate less trash, to cut the costs of disposal, and to contain the costs required to produce new goods. In other words, recycling means creating new values and new meanings. Another cycle and another life. This is where the propulsive contribution of recycling lies. The recycling paradigm offsets the paradigms of new construction and demolition that have dominated modernity, but not in an ordinary way. What is important is to look at those experiences that, thanks to a recycle process, are capable to increase the culture of the city, beauty and urban quality, in relation to specific places and conditions. Architecture and the city have always recycled themselves also in ancient times. Examples like Split (Croatia), Teatro Marcello in Rome or the Cathedral of Syracuse are just a few of the most obvious manifestos of recycling. It's not a question of restoration is a resonance capacity of site to embed new programmes, new vitality, new players and flows of action.

The practice of reCITYing improve these conditions on spatial and creative level: it's an augmented contextual and adaptive practice, so that it can restore value to wasted urban fabrics, infrastructural assets, vacant areas and underused buildings, portions of a previous functional idea of the city which is no more. It brings along the concept of creative knowledge and urban transformation generated over time, focusing on specific site-condition.

ReCITYing actions cannot be carried out by using stereotyped methods or traditional tools. Each place and each case provide the context for a different project. We might speak of different tactics implies new stories to be told and a new course, or maybe multiple stories which can be investigated and performed, involving narratives more than measure (a tool which is familiar to architects and designers). In Genoa, the no-longer-used heritage and urban facilities are a real opportunity, which occupies the most central areas in the city, between the sea and the mountains. Thus, the first objective of the reCITYing Genoa Team has been to evaluate the consistency and the potential of this urban assets such as Albergo dei Poveri.

ReCITYing Genoa Workshop investigated how design based on creativity, recycling practices, arts performances and innovation, can foster new experiences and place-making effects. Conviviality, team works and social participation, have characterised this experience by enabling alternative scenarios of temporary reuse practices together with promoting a new idea sense of the place. 17 proof-of-concepts have been realised in 3-days intensive work, cross-exchange and performance creation. These report collects the series of proof-of-concept elaborated by more than 100 participants mostly composed by young creatives, architects, designers and scenographers, who actively participated the ReCITYing Genoa Workshop. Among these, some projects have been selected with a "Special mention" by an International Jury composed by ReCITYing partners, invited experts and guest critiques from Accademia Ligustica di Belle Arti, Teatro Nazionale Genova, ASP Emanuele Brignole, UniGE tutors and local stakeholders from Genoa Municipality.



## INTHREADS

15

Camilla Martino | Daniel Nanini | Jia Elisa Xu |  
Ludovica Rebolino

Our project, called Inthreads, is an installation that metaphorically represents fast fashion. In our concept, 50 cylindrical elements are hung throughout the courtyard of the "Albergo dei Poveri," made with colorful threads, creating a contrast with the cold and rigorous environment of the building. Visitors can observe and touch the hanging elements, as well as "enter" them by wearing them. The cylinders are made from materials that can stimulate the senses of sight, touch, hearing, and smell, using threads with different textures made from sustainable or recycled materials. The multitude of elements is a critique of the excessive consumerism in the fashion world. Through the materials used, this message also encourages more conscientious purchasing decisions, such as reusing or recycling clothes, or choosing garments produced in a more sustainable way.

The Inthreads installation consists of a series of cylindrical elements that, in the Albergo dei Poveri, are suspended on cables stretched from one window to another. The structure of the cylinders is formed by rigid circles, which can be used in different diameters to create various shapes, with colorful threads stretched over them. The cylinders are suspended from cables attached to four anchor points on the upper circle. The cylinders come in different shapes and sizes, in order to create a dynamic scene and to adapt to people of every height. Walking through a landscape characterized by a series of suspended cylindrical structures of varying diameters and shapes, made from threads of different colors, shapes, sizes, and materials. These structures, with their diverse sizes and configurations, not only capture visual attention but also invite visitors to explore and interact with them. Visitors can walk around the tubes, enter them, and touch them.

Each tube is designed to stimulate certain human senses—sight, touch, smell, and hearing—creating a truly sensory and immersive experience. Through the use of varied materials, scents, and vibrant colors, each cylinder offers a distinctive and engaging sensory experience. By using simple materials and easily replicable modules, the sensory tubes can quickly transform urban areas into lively and welcoming spaces that invite the local community to explore, play, and take photos. The project is flexible, with its modular design allowing this concept to be adopted on a large scale, transforming a variety of urban spaces anywhere into zones of inspiration, fun, and human connection.

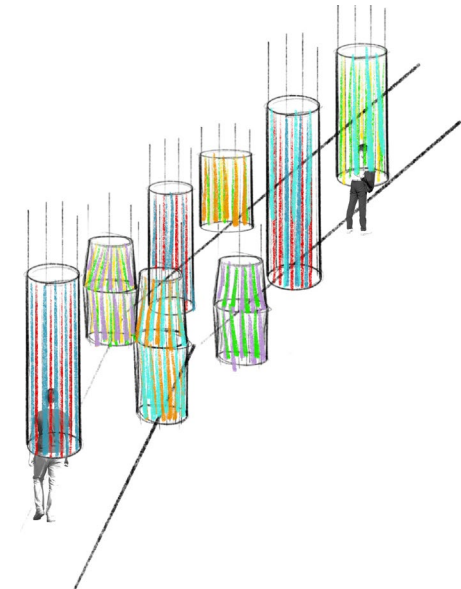

Federico Celia | Federica Miccoli | Ilaria Pagano



**SPECIAL  
MENTION**

The project is based on the historical significance of the Albergo dei Poveri in Genoa, a facility once dedicated to the reception, care, and social reintegration of the less fortunate, those without a place to live.

“Emergency in Gold” aims to offer visitors an immersive experience by hosting them inside a structure made from thermal blankets, known for their durability, lightness, and cost-effectiveness. The journey begins with the observation of the courtyard through the golden filter of the blanket, followed by a performance visible from within the structure itself, during which the visitor awaits the appearance of moving golden figures. The title, “Emergency in Gold,” highlights the concept of emergency related to poverty, while simultaneously evoking a material—the thermal blanket—that, despite being economical and associated with protection and relief, features noble colors such as gold and platinum. The golden blanket transforms the decaying appearance of the Albergo dei Poveri courtyard, symbolically representing the poor in an emergency state, wrapped in a precious and protective material. “Emergency in Gold” thus offers a disorienting experience that compels the visitor to confront the dual image of poverty and preciousness, creating a visual and conceptual dialogue between the dilapidated context and the brilliance of gold.

The development of the project was mainly based on the standard dimensions of emergency blankets. The entire structure is located in the courtyard of the Albergo dei Poveri, following a regular pattern dictated by the size of the courtyard and the number of emergency blanket modules adequate for the available space (approximately 1389 m<sup>2</sup>). The choice of materials was crucial to meet

cost-effectiveness and transportability requirements. The installation was born from the use of emergency blankets, chosen for their physical and technical characteristics, such as the ability to be transparent on one side and darkening on the other when light passes through them. Emergency blanket, commonly known as thermal blanket, is mainly used to induce heat to the human body when no other means of protection are available. However, this material was not chosen for its ability to heat up, but rather for an overlooked peculiarity: its platinum side becomes transparent when in shade. The golden exterior, illuminated by the sun, is not transparent but reflects the light on the walls, covering them with golden reflections. To create the structure, nautical ropes with weights were used, maintaining its lightness and suspended appearance, while the thermal blankets were fixed with double-sided tape. Considering all the materials used, the total expense is minimal compared to the scale of the installation, amounting to approximately 260 euros for this location.

Upon entering, visitors will see photographs of people in difficulty, such as displaced people or immigrants, who have worn these golden blankets due to hardship. The central path opens onto a larger space, creating a meeting place with a long corridor that acts as a showcase for observing the show. They will see the actors wearing these thermal blankets to completely cover their figures. They will interact with visitors through their movements, who will be able to see them clearly thanks to the golden color clearly visible from inside the installation. Finally, the structure ends with a transition passage between interior and exterior, where visitors can see the true appearance of the courtyard.

The project stands out for its notable versatility and adaptability to different contexts. For the proposal presented at the Festival des Architectures Vives (FAV) in Montpellier, the structure was redesigned to integrate with the courtyard of the Hôtel des Trésoriers de la Bourse. The modular configuration includes a short corridor that starts from the gallery and leads to a circular path.

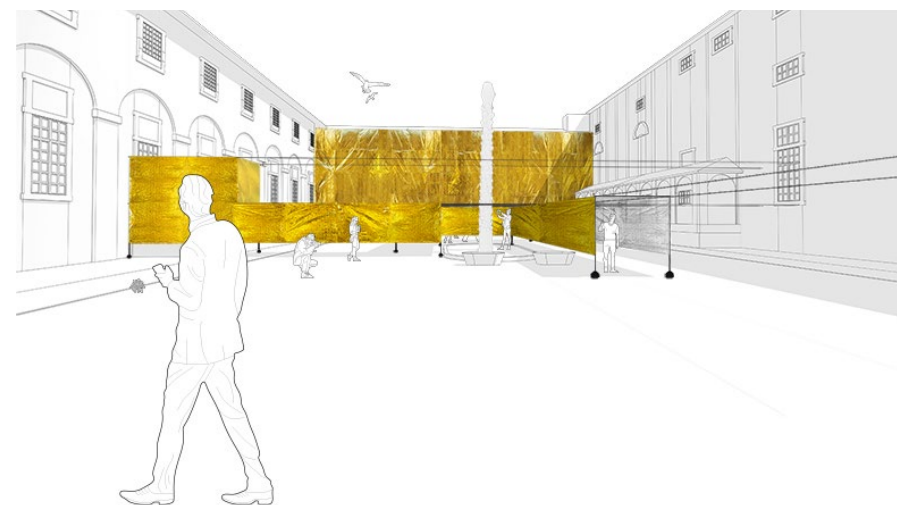

Enrica Bonomo | Simone Clemenzi |  
Francesca D'Ascenzo | Denisa Elena Goga

**SPECIAL MENTION**

The Albergo dei Poveri in Genoa is very famous for its architecture and history. The latter praises especially the benefactors who made the construction possible. However, the hotel was inhabited by men, women and children from all over the world, each with a personal story to tell but nothing is known about them. The project aims to highlight the uniqueness, richness and complexity of those who, even today, live in similar situations, such as exiles, refugees or fallen from grace, so that no one is reduced to a miserable and insignificant number.

The project was born with the intention of telling the stories of all those who do not have a voice, who are part of the indistinct masses of society. This happens through the choice of a strong and direct communicative language, characterized by symbols and objects that allow you to empathize better with the stories of the protagonists. Storymaking focuses on making sure that the narrated story is truly interpreted and experienced by the target audience. In these terms the goal is to lead viewers and visitors towards an internalization of the events narrated through the setting, the photos, the objects and performance. Symbolic elements such as the mask and the bassoon were chosen to best express the concepts of mass and individual. These, assembled through a system that provides for the anchoring of the mask to a metal stem at the base of which is positioned a tulle bassoon. The mask, 200x300 mm in white polypropylene, has been painted with matt black acrylic RAL 9005.

Masks act as visors through which it is possible to enter the stories of each person. Each of them is represented by a photograph applied to a curved cardboard support in order to amplify the depth of the visual field. In the

holes of the eyes is applied a black tulle that hides the inside. Only by approaching and activating the LED sensor placed inside the mask, the identity comes to life and the visitor can interact with it.

At the base is placed a black tulle bassoon variable dimensions based on content. Also in this case, the interior, consisting of objects of various nature that represent the individual person, will be revealed with the lighting of the LED when it will activate the motion sensor. In the closing of the backpack is applied a plate identifier. The layout design includes different configurations which vary according to the site of intervention. The various structures follow rigid and free schemes suitable for various exhibition or performance situations. This is possible thanks to easy assembly and disassembly of each module. The possible project intervention are three: the corridor and the courtyard of the west wing of the Albergo dei poveri, and the courtyard of the FAV on Montpellier. The provisions of the individual elements are "clustering" of the same. These are inspired by images depicting the different configuration that you create from clustered grouping of people, animals, stars and galaxies based on specific criteria. In the "Hidden Identities" project, the clusters are made up of more or less similar people, united by a turbulent past and a present full of hope and desire ransom. For the construction of the site in Montpellier the project takes a different formal connotation, albeit equal in the concept. To change is the module: this no longer consists of mask but from a transparent plastic sphere containing also an identity (photograph and object), and covered with tulle white through which you can glimpse the contents. The pavement of the courtyard is covered with a plastic laminated mirror that circumscribes the installation area and amplifies the interaction with the visitor, who becomes one among the group's identities.





Alessia Bergaglio | Alessia Orlandi | Alessia Passantino

For this installation, we chose the theme of deforestation to encourage the public to reflect on how human choices shape the fate of the world. The intention is to transform a neglected space into a lively and constantly evolving place, actively involving visitors in the process of regeneration or destruction and, consequently, transformation. Located in the courtyard of Albergo dei Poveri, an area with damaged and neglected walls, the installation aims to bring new life and meaning to this place. By turning it into a symbolic forest, visitors will be able to choose between a path of rebirth and regeneration or one of forest destruction. The installation consists of two key elements: a structure of tensioned strings and various floral origami. The tensioned strings create a suspended roof over the courtyard, offering visitors a unique experience as they walk underneath. This structure extends to the most deteriorated wall of the courtyard, blending seamlessly with it and transforming it into an integral part of the installation. Clusters of origami in different colors and floral shapes hang from the network of strings, filling the structure at various heights and densities, creating a dynamic and vibrant environment. The origami symbolically represent the concept of rebirth and regeneration, while visitors can decide the fate of the forest. Visitors are invited to explore and interact with the installation, walking through it and closely admiring the clusters of origami that make it up. They thus become an integral part of the transformation process, deciding on their own how to interact with the symbolic forest. Possible interactions include adding new origami to the structure, removing existing flowers, or modifying the current ones by adding their own thoughts. In this way, the installation is not only a work of art but also a silent protest aimed at

raising awareness about the devastation of our forests and the importance of recycling and respecting the environment.

Origami (from the Japanese *oru*, to fold, and *kami*, paper) refers to the art of folding paper to create objects, a practice that today uses a few types of folds combined in infinite ways to create models, even highly complex ones. Typically, these models start from a square sheet of paper, which can have different colored sides, and are created without making cuts to the paper. The core of the installation is origami, particularly paper flowers: they become a symbol of rebirth, as if the forest we are creating is populated by these flowers made by people. For this reason, at the heart of the installation is a "do it yourself" area where visitors can create their own origami. Here, they will find everything they need: detailed instructions, recycled paper of various sizes and types, markers to personalize the origami with thoughts, and thread to hang their creations in the forest. The installation is designed to have zero impact on the environment, using scrap materials such as recycled paper and cotton threads or yarn scraps to hang and secure the clusters of origami. Visitors will have access to three explanatory videos with instructions to create origami of varying difficulty. Through a simple question, "What does rebirth mean to you?" the installation is enriched by the personal thoughts, drawings and quotes that visitors enclose in their origami. Each origami added to the symbolic forest represents an individual contribution, transforming the collective effort into a living and vibrant work of art. Every step, every fold, becomes an act of regeneration, a gesture of hope towards a better future. The origami forest is not just an artistic testimony, but a statement of intent, an invitation to reflect on our impact on the environment and the possibility of change through conscious and collective actions.

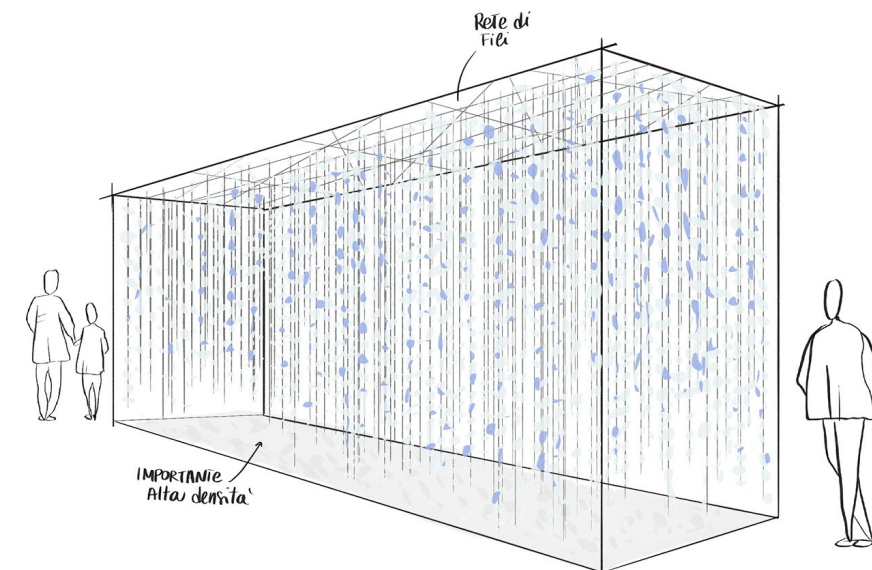

Calderoni Filippo | Cipollini Cecilia | Cirronis Sonia |  
Stentella Alessia

“Un occhio di riguardo” is an immersive art project located at the Albergo dei Poveri in Genoa, a historic place that has welcomed generations of individuals seeking refuge and hope. This project consists of six unique installations, each composed of two concentric frames: a static outer frame and a rotating inner frame, at the center of which is a canvas visually representing a specific emotion. The canvases feature the eye as their main element, symbolizing the soul and serving as a window to human emotions, making each installation a powerful tool for visual communication. The six emotions explored in these installations are hope, joy, sadness, anger, fear, and disgust. These emotions were chosen to reflect the moods of the poor and destitute who came to the Albergo dei Poveri in the 1800s. Each installation offers a glimpse into a complex inner world, providing a journey through which visitors can empathically connect with the experiences of those who lived there. The project aims to create a bridge between the past and the present, using graphics as a tool to explore and understand human emotions. It not only honors the history of the institution but also invites the public to reflect deeply on the fundamental emotions that unite us all. The eyes were chosen as the central element for several profound and symbolic reasons. First, the expression “un occhio di riguardo” refers to special attention to someone’s well-being. This is particularly relevant in the context of our project, carried out in the Albergo dei Poveri, a historical institution that housed destitute people. The living conditions in these places were extremely harsh, and well-being was often an absent concept. The use of eyes is therefore a tribute and a reminder of the need to give attention and care to those less fortunate. The eyes symbolize vigilance and



empathy, crucial elements in the design process to remind us of the importance of creating spaces that promote the well-being of all, regardless of their social and economic conditions. To realize the project, we started with an analysis of the Albergo dei Poveri, a place conceived as a response to the growing poverty and marginalization in the city. Located in the Carignano district, the building, designed by architect Stefano Scaniglia, is an impressive Baroque structure intended to accommodate and assist those in need. From the Albergo dei Poveri history, we decided to find a way to best convey and tell the emotions and stories of those who lived in that place. As already explained previously, the eyes are the chosen means to best convey one's emotions, whether positive or negative.

Furthermore, the eyes can be seen as the eyes of the poor themselves, observing the evolution of society and the vast differences in living conditions today compared to the past. These eyes witness social transformations and injustices, evoking a sense of awareness and reflection on the inequalities still present in our society. On the totem of each installation, there will be postcards, each asking a question. The questions are generic, and visitors will be able to answer and donate a thought. Additionally, mock postage stamps representing the six emotions will be made available. Visitors will have the opportunity to affix the stamp representing the emotion they felt while writing their answer. Once completed, the cards will be placed in a hat, a symbol of poverty (an object often used for begging), highlighting the act of sharing and reflection. This gesture will create an emotional link with the theme of the installation, inviting visitors to actively participate. At the end of the installation, the postcards will be examined to understand how people experience emotions in relation to the questions posed.

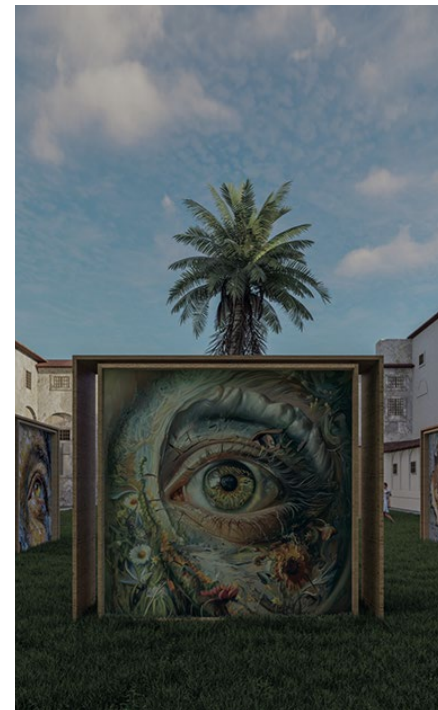



## RESEAING

Giulia Salaris | Lorenzo Sacco | Gabriel Oddone |  
Francesca Vernazza

### **SPECIAL MENTION**

The aim of “Reseaiing” is to give shape to a sea of nets crashing into the urban environment and transform abandoned places into an experience of rediscovery, making people see (or rather revise, hence the name) the places to be recovered in a new light and realising the potential dynamics that these spaces can once again host. The choice of material fell on fishing nets to be disposed of. These are tied and hung in a different way each time, depending on the availability of windows, balconies, per-tuosities or supports in the space, and invite the exploration of this new labyrinth of shapes and colours, thus creating a versatile and changing experience that brings the spaces back to life and creates a bond with it.

The choice fell on the historical relationship between the city and the sea, the world of fishermen and fishing nets. The maritime element has always been characteristic and fundamental for the population of the Ligurian territory, plus the net as an object turns out to be a scenic element of great potential, as it would transport in the ensemble of overlapping and hanging nets a good idea of the sea and allow the net to do its usual job: to retrieve from the space in which it is immersed and thus connect different dimensions (social, historical, etc.).

The material used is traditional fishing nets made of natural fibres such as hemp or cotton and modern nylon fishing nets, all recycled and recovered from local commercial fishing activities. The choice fell back on this type of material in order to create a scenic link with the world of the sea and at the same time be able to create a figurative link with the space: “what did these nets catch from this environment?”. Traditionally, fishing nets were made from natural fibres such as linen, hemp and cotton, but

they were subject to rapid degradation. These still exist today, but synthetic materials such as nylon, polyethylene and polypropylene have become more predominant. The net found for our installation is a traditional type, made of hemp, disused, 3m high and about 100m long. Professional colouring of fishing nets is a fundamental process to improve their durability and functionality. The most common colours are green, blue and brown, chosen to blend in with the marine environment. This treatment not only prolongs the life of the nets, but also optimises their performance, ensuring more sustainable and efficient fishing. In the case of Reseaing, the optional colouring of the nets would be done using different colours and shades to give a greater effect of depth to the installation environment. Transport for urban installation nets follows the normal storage and/or transport of material. Usually, fishermen place them in large, low plastic containers or pack them in bags to be shipped to their destination by transport vehicles.

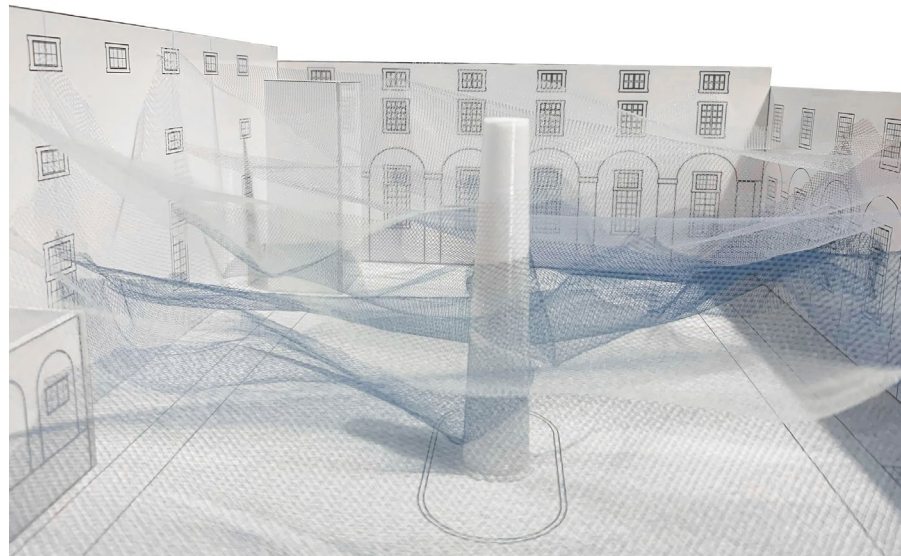

## MANNEQUIN

Alessia Oliveri | Marta Mazzarello | Riccardo Gorza



The heart of our project lies in the concept of philanthropy, a desire to narrate and promote love for others. The Albergo dei Poveri, a symbol of generosity and assistance, becomes the perfect place to denounce cyberbullying and body shaming, conveying positive messages of inclusion, mutual help, and love for yourself and others. The name "MANNEQUIN" highlights the concept of equity by emphasizing the word "EQUI" within it, underscoring the value of equality regardless of physical differences. Through this naming, we aim to promote solidarity, inviting people to celebrate what makes them unique. We have selected real-life stories as examples of strength and resilience. Individuals who have found the courage to face difficult challenges and transform negative experiences into opportunities to comfort, inform, and raise awareness among others. Their testimonies invite us to reflect on the importance of kindness, empathy, and understanding, encouraging us to build a more inclusive and supportive world. To represent these stories we found some references showing projects and installations that use figures and sculptures to convey a message. For example, Hans Boodt Mannequins and Pantone create a synergy between design and color at Fuorisalone 2019. The partnership allows both brands to draw new inspiration from the synergy between color and design; at the same time it allows Hans Boodt Mannequins to work on customization and showcase the endless possibilities in terms of colors, materials and finishes. Instead, for the faces, we were inspired by JR's work "Inside Out," in which he transformed the Panthéon into a work of participatory art. Involving global audiences, JR invited people to send in their portraits, printed in black and white on large posters, then applied to the Panthéon's dome, floors and interior facades. We represent these stories through recycled, unused or ruined mannequins.

If they are not found, alternative you could buy or you could use inflatable mannequins. The latter would also facilitate transport, but the final yield would not be the same. These figures become the centerpiece of an installation. "Skins" personify individuals with physical issues, for example, the loss of a limb, a disability, a disease, highlighted in red paint. QR code will be applied to the mannequins, enabling viewers to discover, read the stories behind each character and the concept of the project; and write your own comment or story in the dedicate section. Four different arrangements have been designed for the mannequins, whose modularity allows for dynamic and creative display solutions, adaptable to various needs. The layout selected for the Albergo dei Poveri consists of 160 mannequins arranged around the central tree of the courtyard. Being a versatile installation, other arrangements were designed. You can see them in the book. We thought of arrangements where visitors could interact and walk around mannequins. To complete the installation, there will be three vertical banners, placed on the facade, containing the faces of the people represented by the mannequins. In this way you give a face and identity to these figures. We are also part of that group. We are equal in our differences.

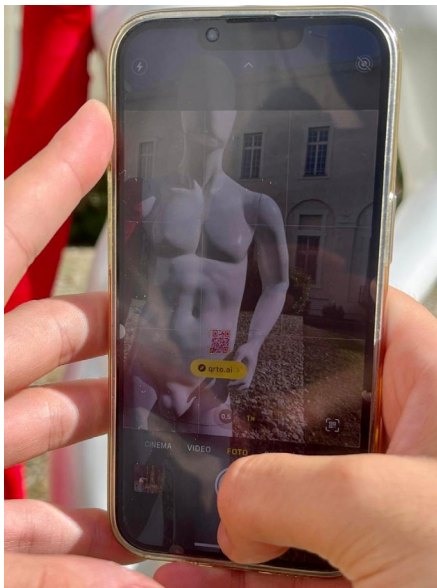
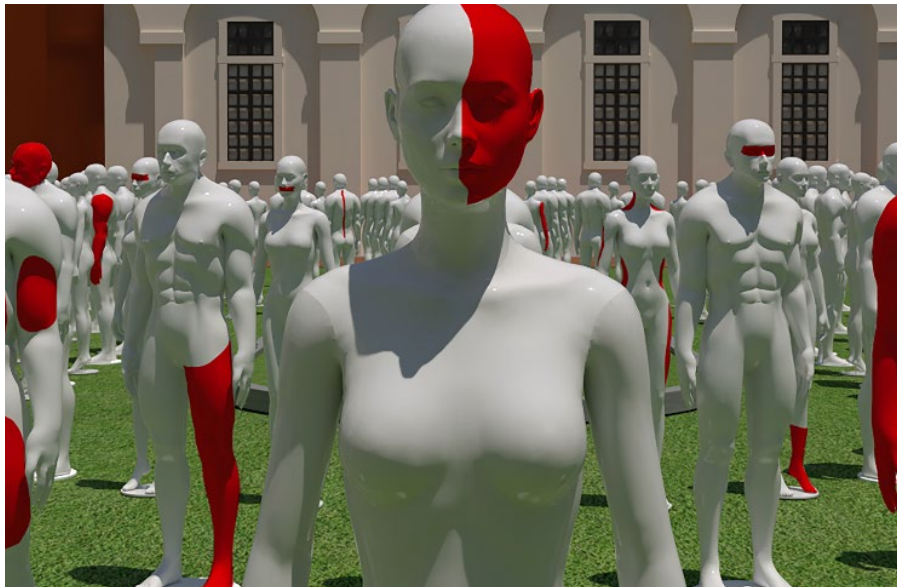
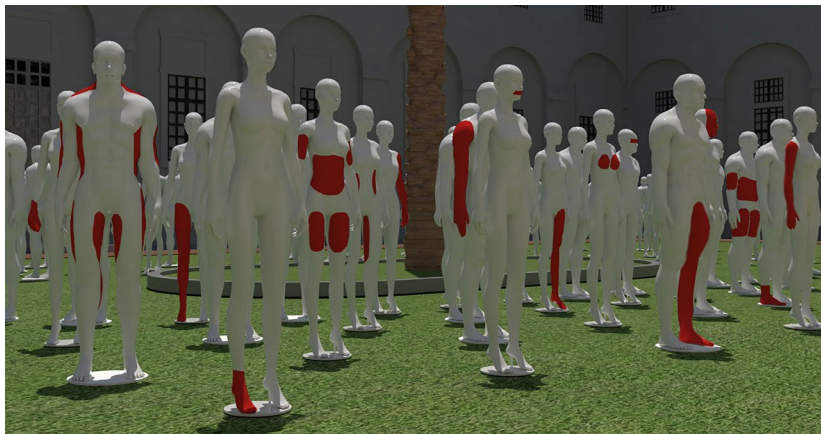



## RED CARPET

43

Aman Gebru Habtyes | Aroldo Silvestri | Haoqi Xu |  
Nadia Baji | Yumeng Xie

The project was born from the necessity to beautify and bring life back to a structure forgotten by its citizens, yet rich in history. The initial idea was to create a line, a ribbon that would wrap around the structure as if it were a gift, evolving into a red carpet that invites those who had forgotten this place to forge new and fascinating memories, rekindling its soul to ensure its history does not fade away.

We have chosen the name "Red Carpet" to contrast with its traditional meaning, a symbol of wealth, splendor, and luxury. Our aim is to break this stigma and bring the red carpet experience to those who have never had the opportunity to walk on it. Similarly, we aspire to introduce the project into buildings that have never hosted a red carpet or only briefly experienced its presence, while still preserving the dignity that a red carpet signifies.

The project is designed to be replicable and easily implementable, using modular pieces and sustainable materials. The reduced costs and the ability to reuse materials without structurally altering the building make the project both accessible and environmentally friendly.

Through this project, we aim to preserve the historical expression and spirit of the building and share it with the world. Our initiative not only enhances the Albergo dei Poveri in Genoa but also aspires to replicate this model in other global contexts, allowing everyone to rediscover and celebrate their own historical and cultural heritage. The goal is to create a bridge between the past and the future, uniting diverse communities through the symbol of the red carpet and the beauty of renewal.

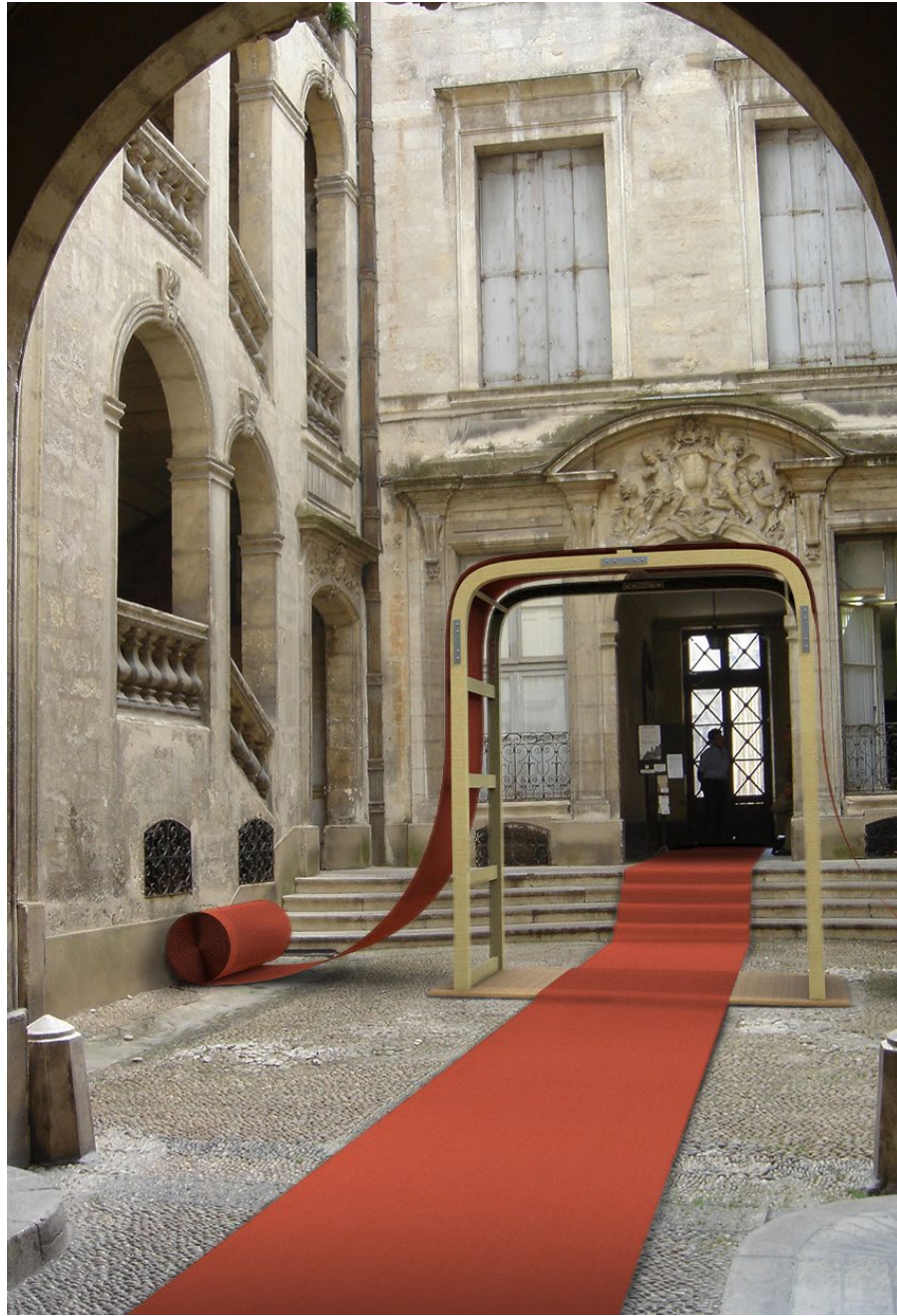
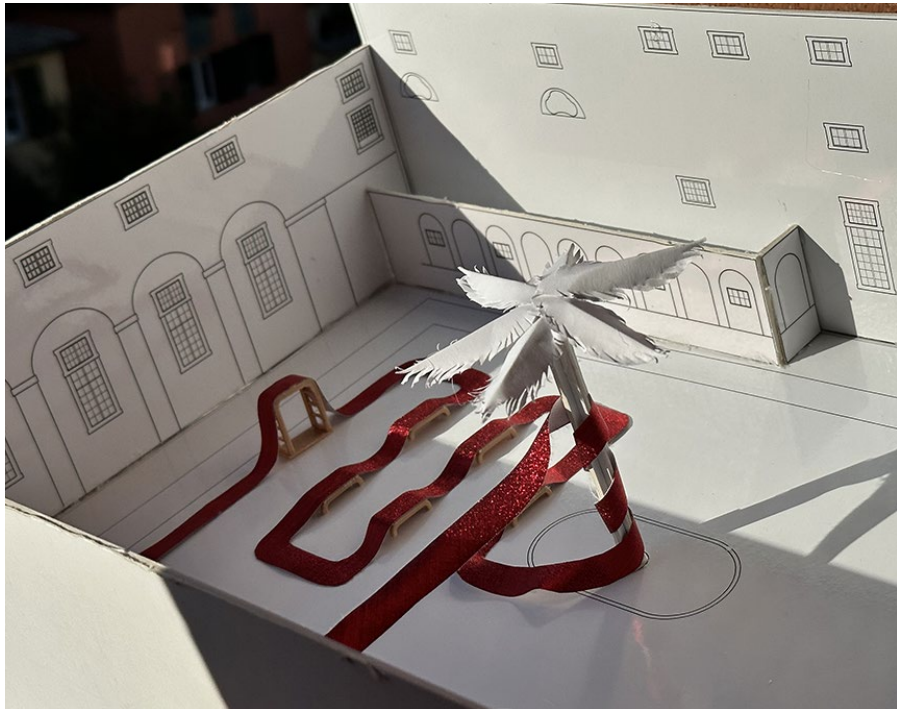
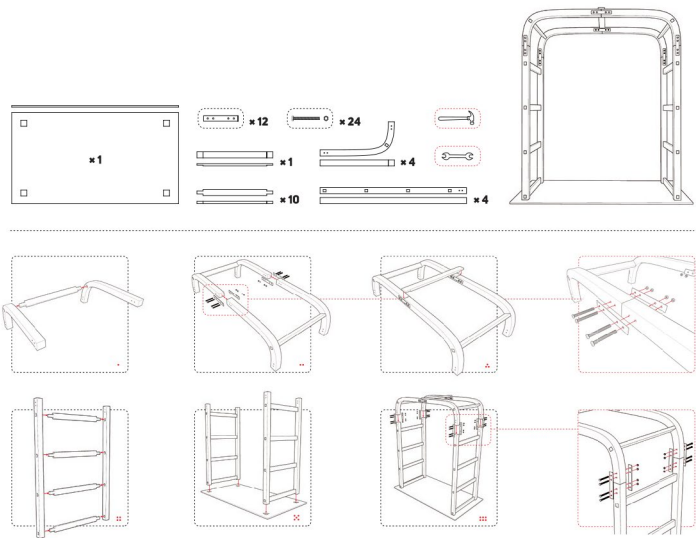

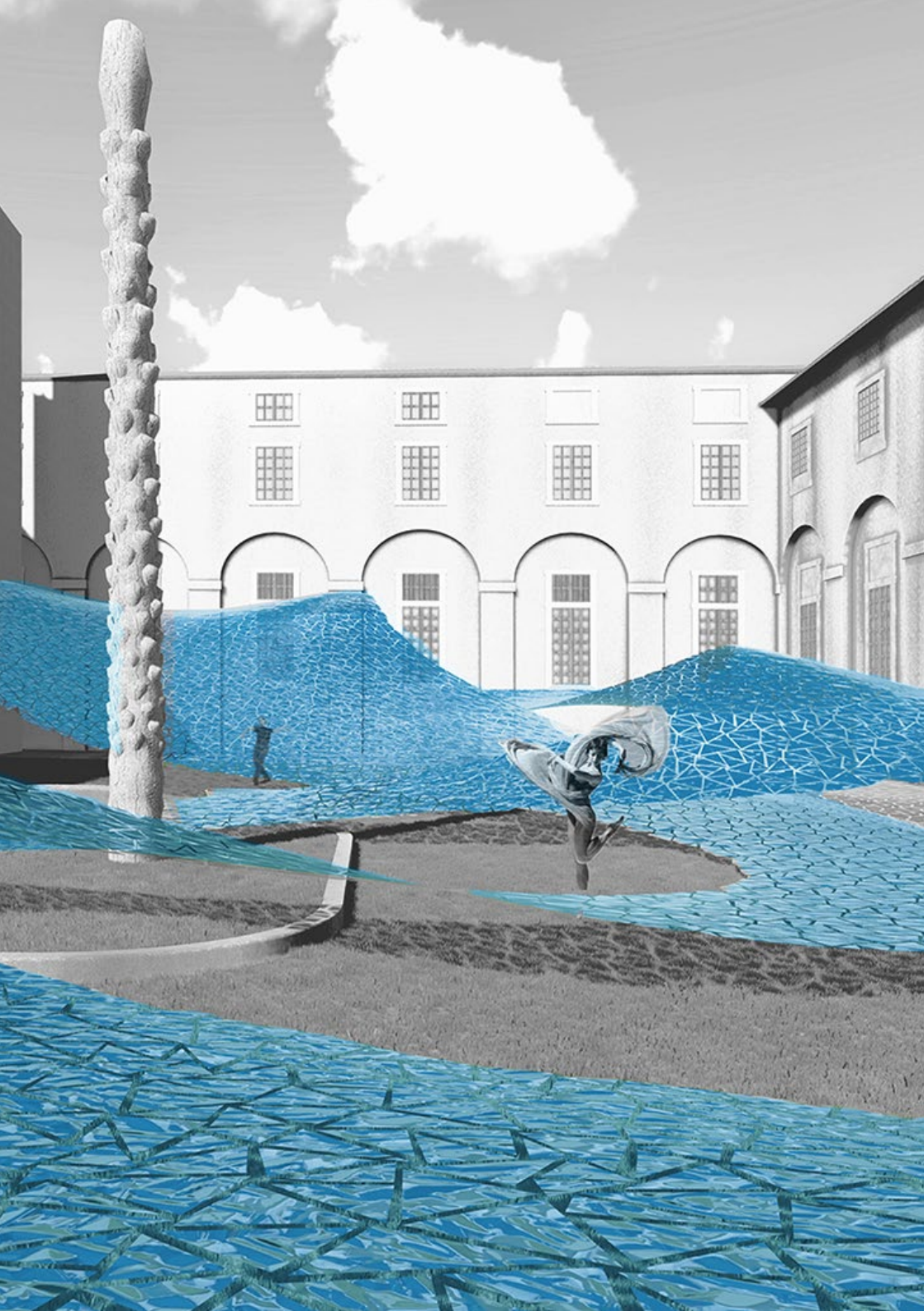

## ONDA

47

Alessia Capetta | Alice Gasparri |  
Maria Giulia Golino

Our project concept is rooted in the idea of transformation, interaction, and immersion. Inspired by the ancient narrative of Hero and Leander, and the dynamic symbolism of waves in Eastern traditions, we aim to create an experience that transcends traditional boundaries between observer and space. Waves, as symbols of eternal movement and transformation, become the guiding metaphor for our design, representing the constant duality between being and becoming, love and loss, as well as change and continuity.

Our proposal reimagines the abandoned courtyard of Albergo dei Poveri as a vibrant, multisensory environment that brings the legend of Hero and Leander to life. This space is transformed into an immersive stage that invites the audience to engage with the beauty and complexity of this timeless story. By using a careful play of light and shadow, we create a captivating atmosphere that draws in spectators and stimulates their imagination, encouraging them to explore the narrative in new and unexpected ways. The structure is not just a visual installation, but an interactive experience. Sound elements are woven into the design, creating a harmonious connection between the space, the audience, and the environment.

Every aspect of the project has been designed with the intent to foster interaction and immersion. Visitors are invited to explore and connect with both the space and each other in surprising ways, discovering new layers of meaning and experience as they move through the environment. The structure thus becomes more than just an artistic installation; it becomes a participatory experience, one that transforms physical space into a living narrative, encouraging a deeper connection with the themes of love, transformation, and the passage of time.

The concept has been developed in a flexible manner, designed to be adaptable to various forms and contexts, ensuring its versatility and suitability for different situations and locations.

This flexibility allows the installation to seamlessly integrate into urban environments, public spaces, or natural settings, offering unique and engaging experiences wherever it is hosted.

Furthermore, the multifaceted nature of the installation allows it to be tailored to different purposes and uses, based on the specific needs of the location and the people involved. Whether it's an artistic installation, a tourist attraction, an educational tool, or an urban furnishing element, the concept can be customized to meet a wide range of needs and objectives.

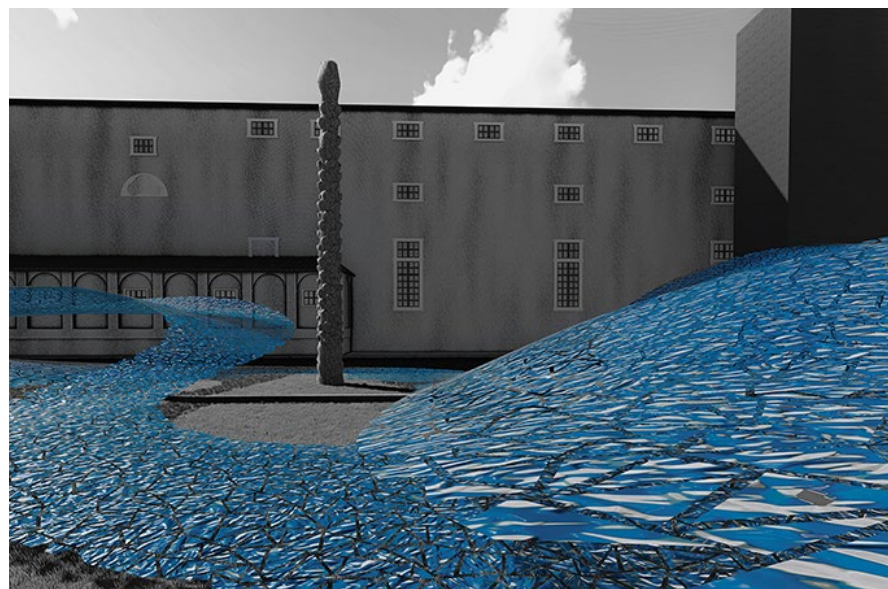
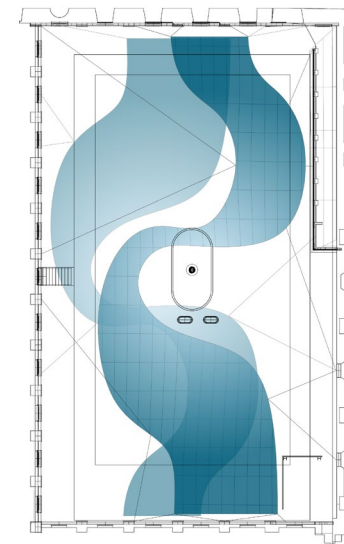
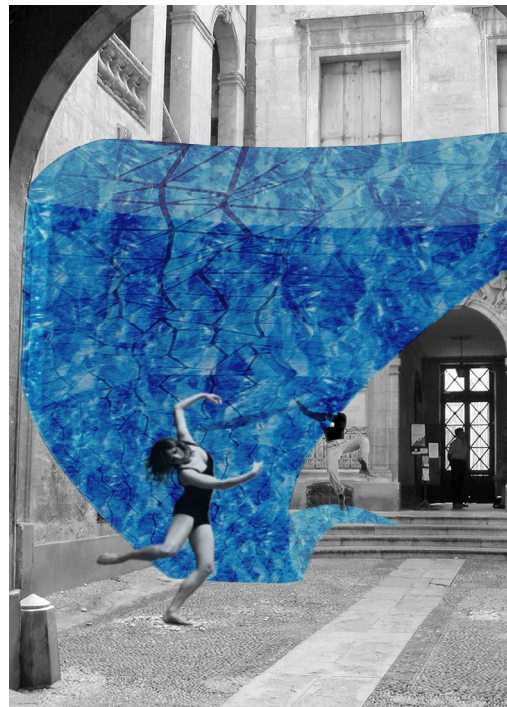



## OLTRE L'OMBRA

51

Pietro Carena | Desirée Carrieri  
Sofia Genesin | Aurora Tenca

For the project "ReCITYing. Reactivating unused urban spaces through architecture and arts," our team developed a project in the Product Design 1 course that honors those who lived in the Albergo dei Poveri. We created a memory of the past residents through shadows, guiding visitors via a modular, labyrinthine path to an artistic performance. This path, made of steel tubes supporting taut fabrics, evokes the building's historic manufacturing processes. The structure resumes key elements of the Albergo dei Poveri, such as the church dome, the Greek cross plan and the internal courtyards. It also resembles the Shakespearean theatre's circular, roofless courtyard. If space for the performance is limited, one curved section can be removed to create seating areas. The structure uses steel for support, chosen for its recyclability and energy efficiency. The fabric is "ASL - Light Scenario" from Peroni S.p.a., a white cotton muslin with a sparse, semi-transparent texture. (It provides projection effects similar to tulle but with a unique character when backlit). The modular design ensures easy disassembly and storage in a container with dimensions: 5.90 m (length), 2.35 m (width), and 2.39 m (height). The main structure's modules can be rearranged to suit different spaces, needs, and performance types. For FAV, we adapted the design to fit an internal courtyard by using only selected modules: two curved and two angled components. This smaller, intimate setup, viewed from above, resembles a human eye, symbolizing the vision beyond the earthly realm and reminding us of the lives of past residents.

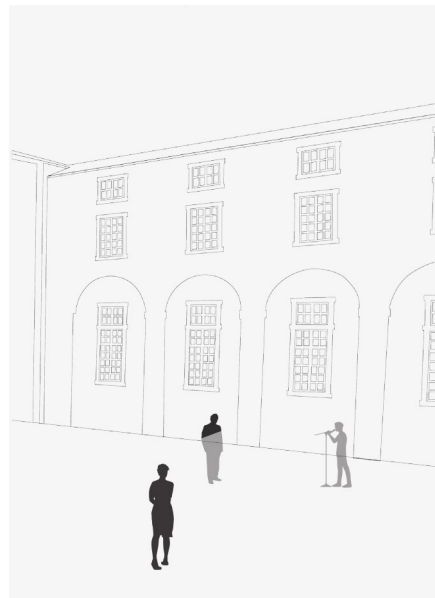
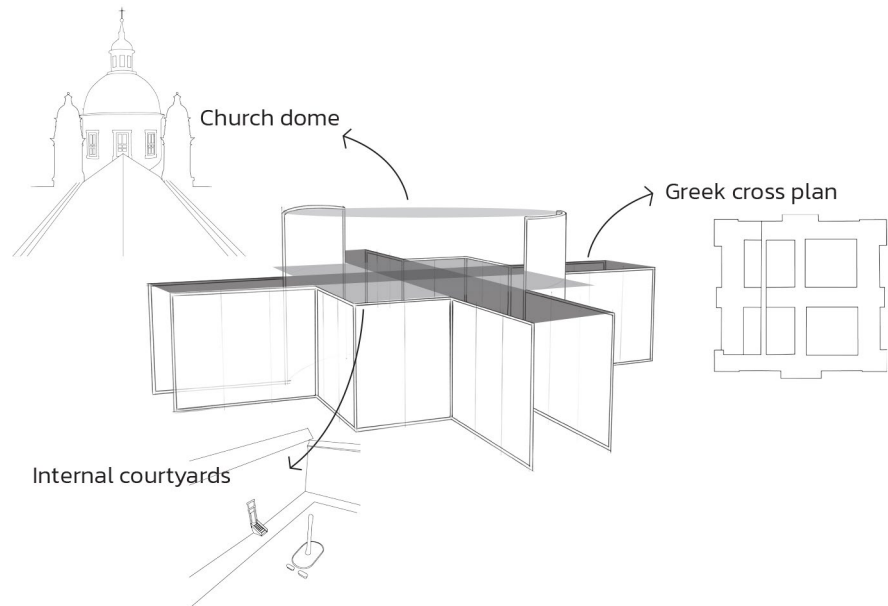
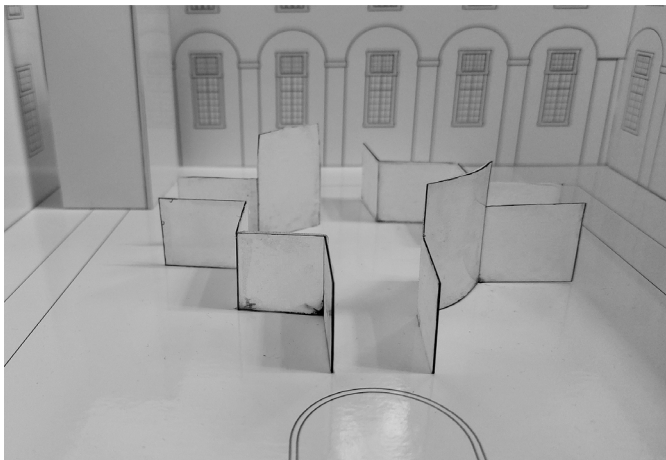
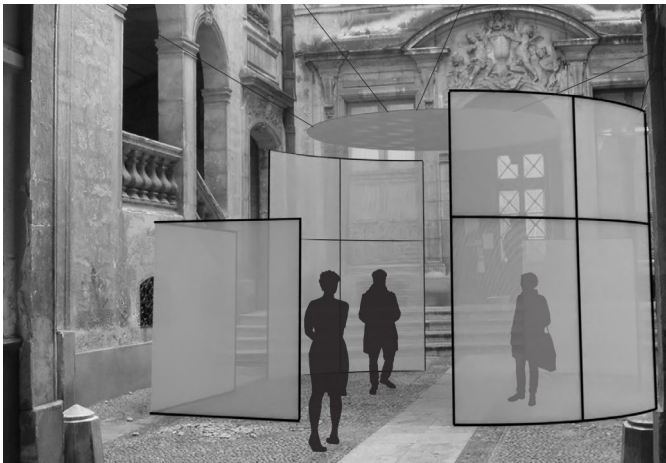

## CARBASAS

Collaborate, paint and color your city with non-invasive street art

Federica Casu | Morgan Girelli  
Maria Valentina Marino | Vincenzo Galtieri

Carbasas is an interactive installation designed to turn art into a collective experience. On a solid wooden platform, poles stand supporting a large canvas, ready to come life through the shared creativity of the participants. Artists have drawn initial guidelines on this canvas, providing a base on which visitors can express their own whimsy. Following the artists' directions, participants add their personal touch, contributing to a work of art that is as much theirs as it is the artists'. At the 'end of the event, the canvases created by the street artists and participants will have a second life rich in meaning and functionality. These unique works of art will not simply be displayed, but integrated into the urban fabric in a non-invasive way. The painted canvases will not permanently cover the walls of buildings, but will be hung temporarily on buildings or used as covers for construction sites. This approach respects urban architecture, preserving the integrity of historic and modern buildings. In addition, the flexibility of the canvases allows for continuous evolution of art displays, reducing environmental impact compared to the use of permanent paints. An application was created to involve as many people as possible, where there is an explanation of the project, its origins and the collaborations that make it possible. Then, the cities where the work will be installed, the canvases made during the event and the artist of these that guided the visitor during the moment of creation are indicated.



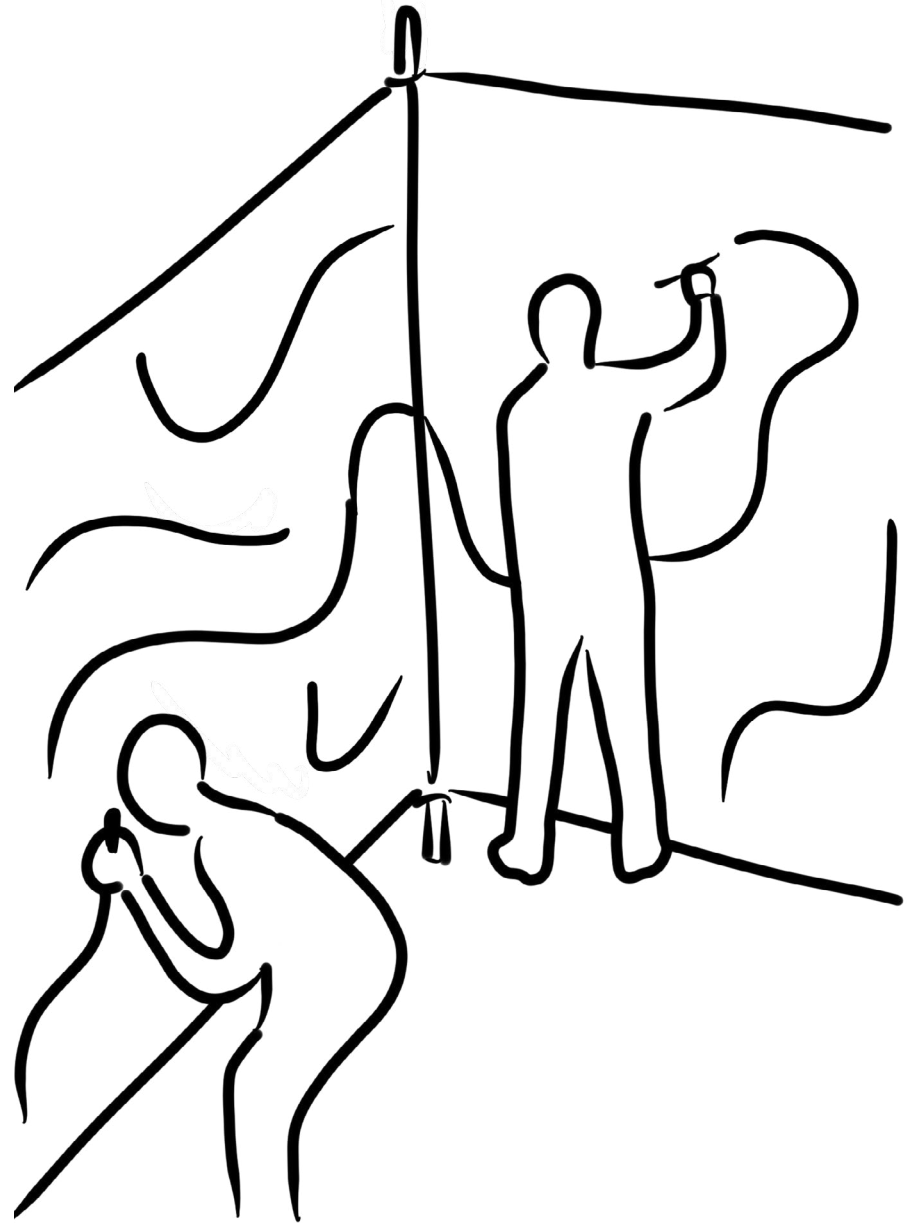

Discover the event on the website





## [HUG] GREGATION

59

Marta Ascheri | Valeria Camperi  
Serena Macciò | Alina Sinchuk

### SPECIAL MENTION

The project was born from the concept of union, of which a positive example is the AdP, a model of assistance, but also of relaunching the city. Inspired by Emanuele Brignole's dedication to helping the invisible, two equal solids were represented, distinguished by color, which when joined together perfectly intertwine to form a single block. This block represents the community and is mind food on the importance of learning to see and support the most fragile. The term "invisible" refers to those whom society, for various reasons, does not see or refuses to see. Sometimes, society forgets unlucky people and those in difficulty, rewarding and giving visibility only to those who flaunt and show off. In the past, as in the case of the AdP, the invisible were orphans, poor or sick people. Today, we can include many other categories: the disabled, the elderly, refugees, and those with serious addictions. This is the message we want to convey: to raise awareness in the community to learn to "see" those around us. The scutoid allows the creation of temporary structures for events, both outdoors and indoors, also thanks to the use of a plastic material, resistant to atmospheric agents. For our project we decided to use recycled plastic associated with 3D printing. Inside, the modules are empty to facilitate movement and transport. We have combined four different colors with the transparent module, all inspired by typical Ligurian homes. Thanks to this strategy, the philosophy of [HUG] gregation can be exported to various contexts and cities, even abroad, simply by attributing different colors, but always maintaining the duality between transparent and colour. [HUG] gregation is not only an activating object, but a philosophy that creates a real dialogue between past and present, between local identity and innovation.

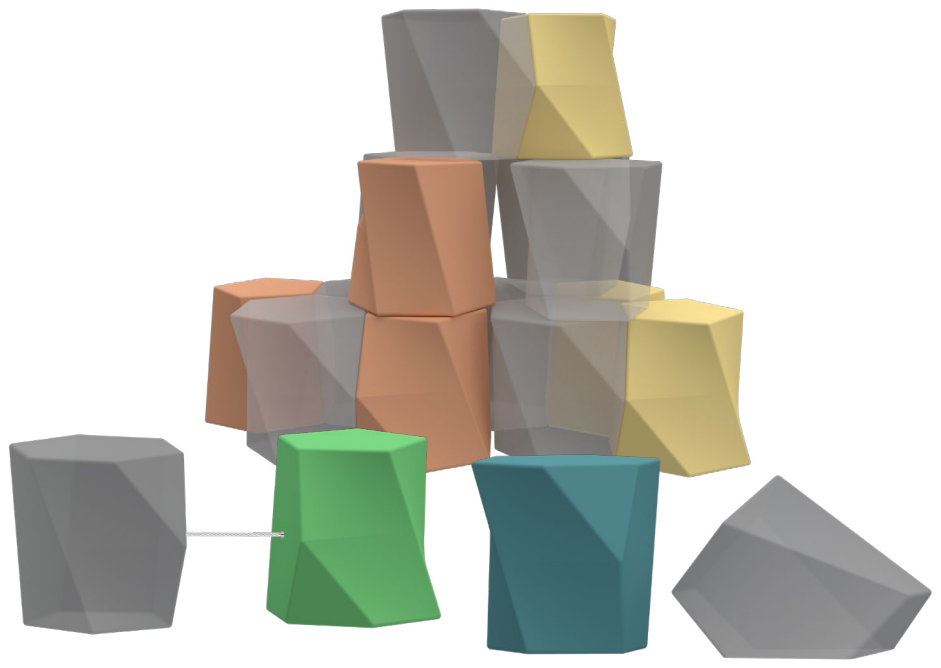
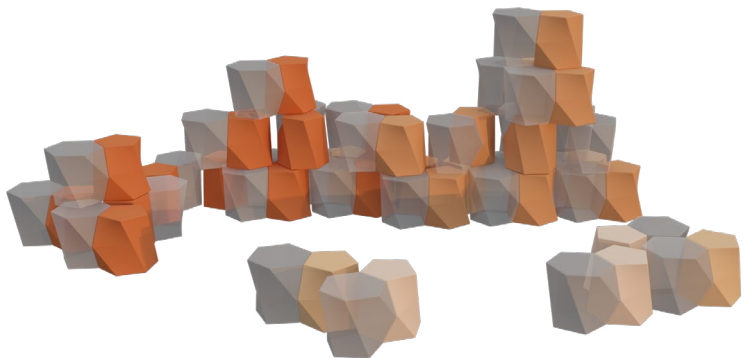



## NEMA

### Exploring, Restitching and Twining the urban tissue

Amelii Lorenzo | Bernat Marco |  
Pillepich Francesco

The installation project in the garden of the Albergo dei Poveri is based on weaving and stitching, echoing the historic tailoring training provided to young residents. The goal is to merge history with modernity, revitalizing a decaying part of the building and reintegrating it into the urban fabric. Designed to be modular and dismantlable, the installation allows for easy reconfiguration in other contexts, ensuring adaptability to various environments. This approach maintains the concept of urban stitching and fosters new interactions between the building and visitors.

The objectives are:

1. Cultural and Historical Valorization: Revive the themes of the Albergo dei Poveri's training and tailoring tradition.
2. Urban Redevelopment: Breathe new life into a decayed part of the building, stitching it back into Genoa's urban context.
3. Interaction and Engagement: Create an interactive experience for visitors using symbolic and evocative installations.

The project features a path guided by a red thread, symbolizing Ariadne's thread, inviting visitors to explore the garden and building. This thread represents the link between past and present, history and modernity, supported by three totemic structures inspired by the Fates of Greek mythology:

1. Lachesis - The Spool: symbolizing the weaving of destiny, which marks the beginning of the path, welcoming visitors and introducing the concept of weaving and history.
2. Atropos - The Seat: A structure that supports the thread, symbolizing the seat where sewing work was done,

acting as a point of reflection and rest for visitors, allowing them to immerse in the history of the Albergo.  
 3. Clotho - The Needle: A structure representing the needle, symbolizing the closure of the thread. It concludes the path, symbolizing the end of the journey and the stitching of the building back into the urban fabric.

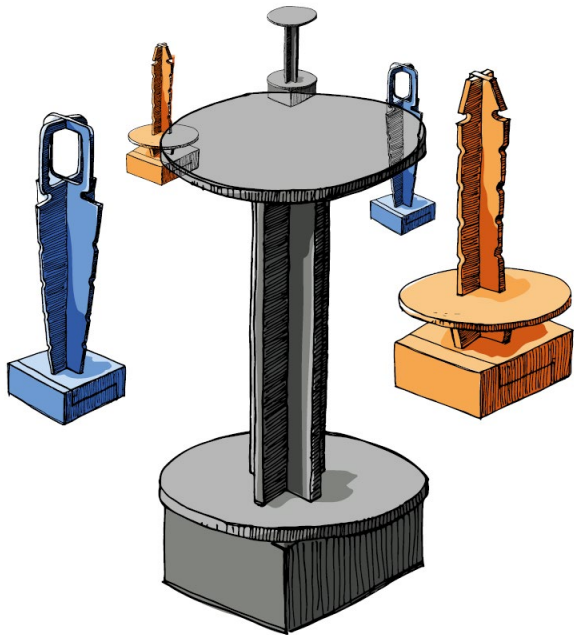

Video of the process



Production via CNC Cutting of the 1:10 scale model and demonstration of the interlocking of the various pieces



Some rendered views of the installation inside the garden of ADP, in which are represented the various activities and interactions between the visitors and the structures



Render of the installation inside the courtyard of the FAV in Montpellier



Veronica Bracco | Francesca Falabella  
Alexia Formica | Ludovica Gentili

### **SPECIAL MENTION**

The Albergo dei Poveri, a site rich in history but currently in decay, clearly reveals its essence through its remnants. The emotions experienced during the visit to this space sparked creativity, leading to the exploration of different options for its reactivation, beginning with the concept of the fragment.

The installation seeks to emphasize the importance of each individual fragment from the building, as well as the lives of those who once inhabited the space. These fragments, shaped by neglect and the passage of time, hold memories, values, and emotions from the past. The wealth hidden in these fragments lies in the eyes of those who carefully observe and appreciate them, becoming cognitive instruments that connect with the place. The installation comprises multiple mobile modules in the garden, two macrostructures in the northeast and southwest corners of the courtyard, and a freestanding structure in the middle, straddling the flowerbed. The modular design, based on a pyramid module with a triangular base, consists of six tubes and four joints made of matte black aluminum, a panel of reflective aluminum or COR-TEN steel, and twelve screws.

This design represents the archetype of the entire structure, allowing a complex system to emerge from simple forms. The chosen materials—Corten steel and aluminum—are fully recyclable, maintaining their properties indefinitely. Corten steel is natural, sustainable, cost-effective, and weather-resistant, while aluminum is abundant, lightweight, corrosion-resistant, and reflective. These durable and versatile materials not only reduce waste and conserve resources but also carry unique histories, perfectly aligning with the mission of revitalizing abandoned spaces.

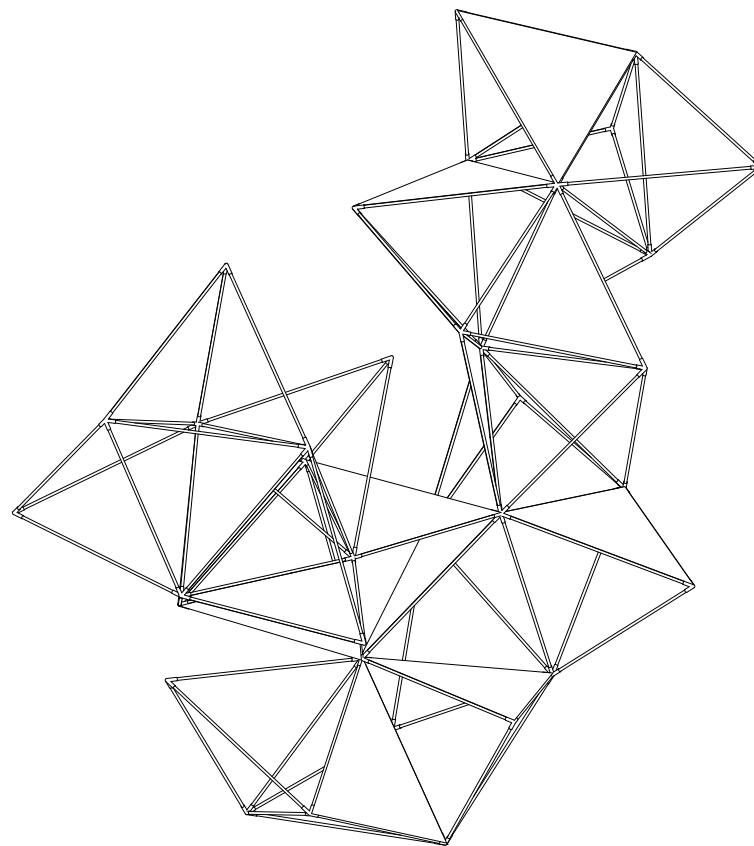

## ECO Sistema

Giacomo Costigliolo | Giovanni d'Erba |  
Nicole Lomuscio | Syria Vannini

ECOsistema is a hexagonal structure that ensures stability and recalls natural symmetry, facilitating a harmonious distribution of space that combines functionality and aesthetics. The sensory experience is amplified thanks to the infinity mirrors and mirrored water pools. The suggestion of the sound box, reinterpreted in a poetic way, offers users a different perspective, enhanced by the play of light in the water and the infinity mirrors.

The project allows users to climb, sit, or lie down. Interaction with the structure activates motion sensors that turn on the infinity mirrors located in some of the hexagons, enticing users to explore and discover all the mirrors. The tubulars are available in four lengths: 250 mm, 500 mm, 1300 mm, and 2200 mm, all with a 60 mm section. Each component is designed for maximum usability. The shorter tubulars are accessible to children; the 500 mm tubulars are for ergonomic seating; the 1300 mm intermediate tubulars facilitate access to the highest points, the 2200 mm tubulars. During assembly, the highest tubulars should be in the center to prevent falls, with intermediate sizes positioned around them. ECOSistema's design emphasizes ease of transport and storage. Components are made from lightweight materials like aluminum, polyester, and polyethylene, reducing transport costs and facilitating handling and assembly. They are organized inside lightweight cardboard boxes to minimize bulk. The structure is based on a pyramid module with a triangular base and consists of six tubes and four joints made of matt black aluminium, one panel of more or less reflective aluminium or COR-TEN steel and twelve screws. The materials chosen are 100% recyclable and can be reused an infinite number of times while retaining their properties.





## SHAPING FRAGMENTED ASSETS

Claudio Cervetto | Giorgia Grasso | Ginevra Mignano

### SPECIAL MENTION

Inside the Albergo dei Poveri, imposing statues pay homage to the benefactors who, with a great gesture of humanity and generosity, supported the project to welcome the needy. However, for those who do not know their history, these statues could arouse a sense of superiority and privilege, conveying a message opposite to that originally intended. For this reason, it is aimed at canceling this possible misperception. Drawing inspiration from the concept of monumental fragmentation and statuary, the initiative aims to convey a deeper meaning. The metaphor of a large statue that fragments into many pieces is considered. A vision that represents the assets possessed by the individual benefactor, who fragments it and shares it with all the refugees.

The project consists of a large block, similar to a statuary base, fragmented into 9 modules. These modules are designed to be moved, grouped, rotated and overturned, allowing visitors to create an ideal shared environment. People collaborate and experiment with their creativity, forming infinite spaces that reflect their needs. A continuous process that gives life to a space in continuous transformation, recalling the historical value of the Albergo dei Poveri. The aim is to highlight that everyone, in doing and sharing, can create works and become statues like the giants of Genoese charity.

Those benefactors, who in the collective, together with all the refugees, managed to create the great work of humanity and sharing. A work that has indelibly etched the great history of the Albergo dei Poveri. The sizes of the modules do not exceed 220 cm in height. Six modules feature interlocking assembly with velcro applied at the joints to ensure a secure fit. The other three modules, due to their small size, do not require any assembly.

The FAV Project is a giant 8-cubic-meter cube made of recycled polyurethane. Using sensors, the cube will react to the presence of visitors and invite them to fragment it into many pieces to reflect the concept of fragmentation of the benefactors' assets.

Then, People will scan a QR Code and watch a video that will quickly explain the concept of the project through a fast sequence of images.



TRANSPORT - ASSEMBLY

MATERIALS

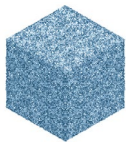
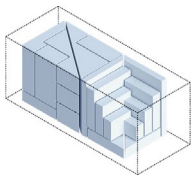

Container insertion

Interlocking assembly

Recycled polyurethane

Polyurea (coating)

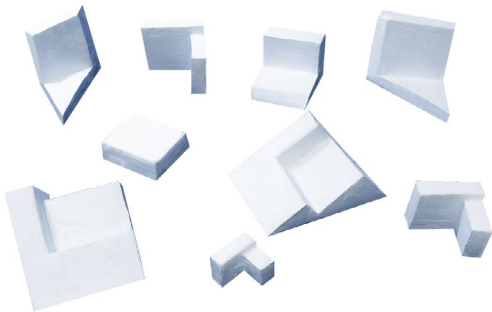



## f-LUX

79

Marianna Bruzzone | Giorgia Grasso  
Daniele Mulas | Vanessa Zuffada

“Albergo dei Poveri” is a structure that for centuries has dominated the Genoese landscape, so much so as to be one of the first buildings visible to sailors who approached the coast of Genoa. Through the central hall of the building, visitors can admire the blue of the Ligurian Sea sparkling in the distance.

Plankton, small marine organisms known for their bioluminescence, are the central reference of the f-LUX installation. These living beings, with their natural lights not only contribute to the chromatic aspect of the work, but also embody the theme of migration, since they are the species that migrate the most.

Montpellier and Genoa, the cities that will host the installation, are closely linked to the theme of migration, being both port cities overlooking the Mediterranean Sea, symbol par excellence of migration.

The f-LUX installation was born from the exploration of this deep link between “Albergo dei Poveri” and the sea. It develops as an undulating path that visitors can cross to reach the performance area.

This undulating path represents the journey and the possibility of getting lost and finding refuge in the concavity of the walls of the installation, similar to protective shells.

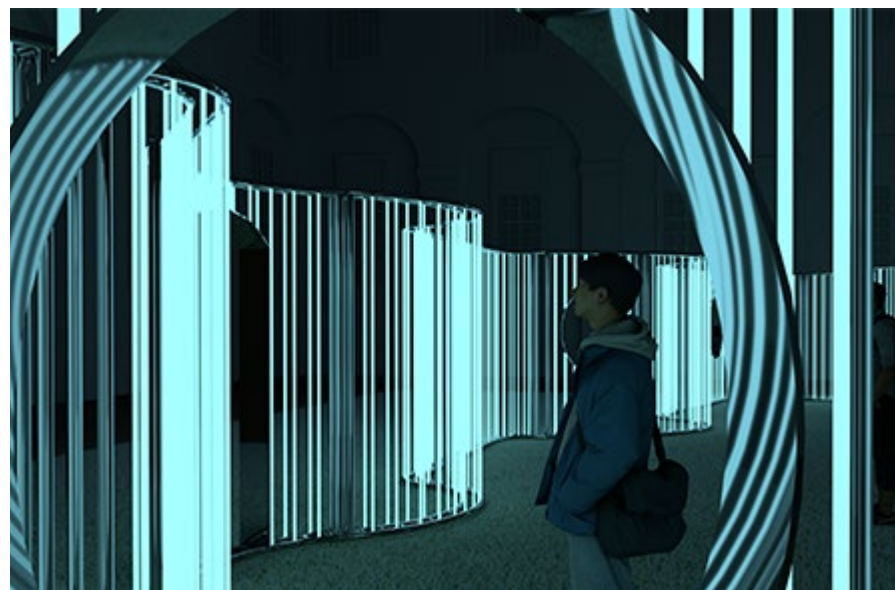
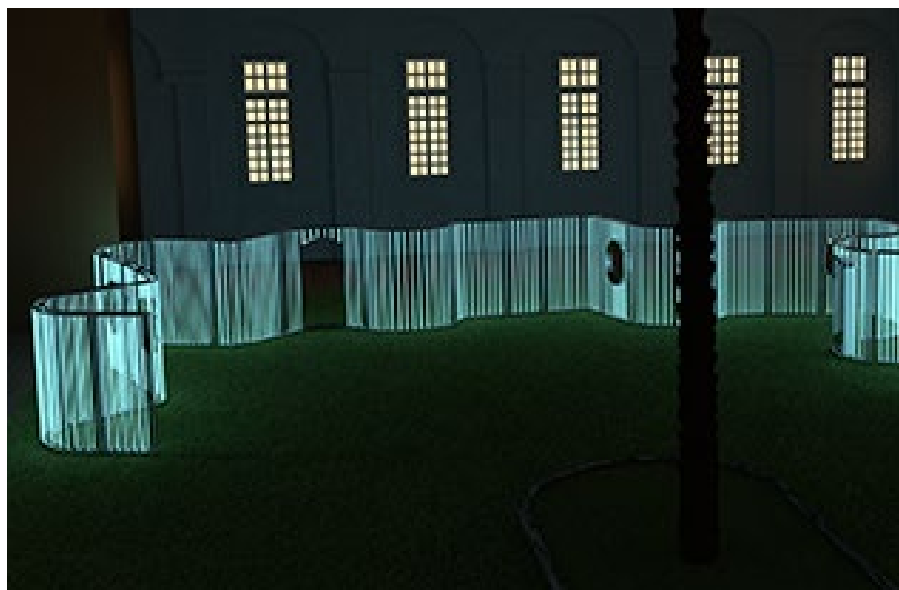
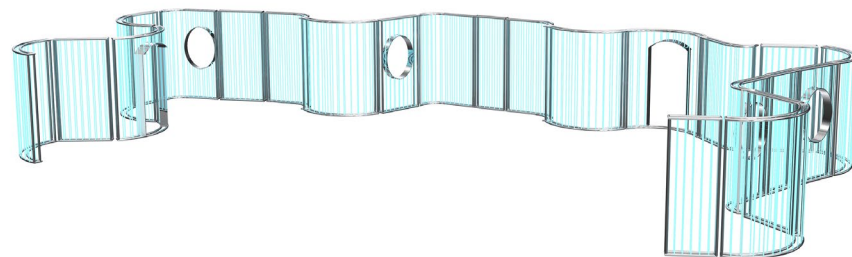
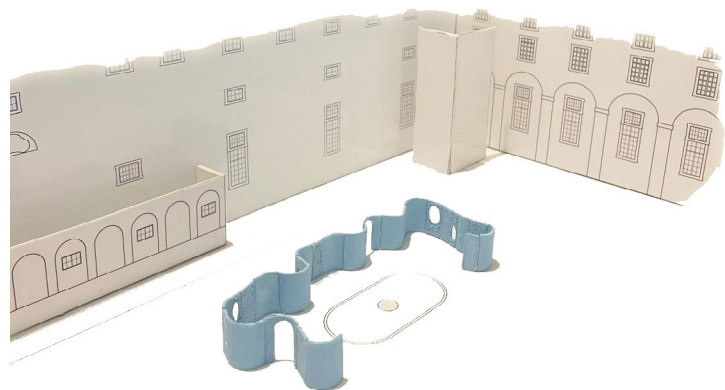

## INSTRUCTOR AND EXPERTS

Università degli Studi di Genova UniGE-DAD:

**Manuel Gausa** | ReC Principal Investigator  
*Advanced Urbanism Expert*

**Emanuele Sommariva** | ReC Co-PI, UniGe Scientific Coordinator  
*Urban Recycle & Metabolism Expert*

**Nicola V. Canessa** | UniGe Scientific Coordinator  
*Urban and Architectural Design Expert*

**Silvia Pericu** | ReC Artistic Director  
*Citizen participation Expert*

**Giorgia Tucci** | ReC Project Manager  
*Urban co-design practices Expert*

**Chiara Olivastri** | ReC Communication Officer  
*Service design and Communication Expert*

**Giovanna Tagliasco** | ReC Communication Secretary  
*Graphic and Visualization Expert*

**Stella F. Rigo** | ReC Communication Secretary  
*Graphic and Visualization Expert*

**Chiara Centanaro** | ReC Scientific Secretary  
*Urban co-design practices expert*

with

Federica Delprino | ReC UniGe Tutor

Omar Tonella | ReC UniGe Tutor

Chiara Maresca | ReC UniGe Tutor

## External Experts:

**Lisetta Buccellato Lisetta** | Scenographer & Costume designer, Paris

**Marc Aureli Santos** | Ajuntament de Barcelona, Barcelona

**Guido Fiorato** | Accademia Ligustica Belle Arti, Genova

**Anna Varaldo Anna** | Accademia Ligustica Belle Arti, Genova

**Carlo Sciacaluga** | Stage director & Teatro Nazionale, Genova

**Marco Sinesi** | ASP Emanuele Brignole Comissioner, Genova

**Annamaria De Marini** | ASP Emanuele Brignole, Genova

## ReCITYing (ReC) Partners:

**Laura Guimarães** | IAAC, Barcelona

*Resilient Urban Metabolism Expert, Barcelona*

**Gallego Ana** | IAAC, Barcelona

*Advanced Information and Communication Expert*

**Jörg Schröder** | LUH | Hannover

*Territorial & Circular Design Expert*

**Scaffidi Federica** | LUH, Hannover

*Urban Recycle Expert*

**Vidmar Simona** | UGM, Maribor

*Art-installation Design Expert*

**Stojan Skalicky** | UGM, Maribor

*Architectural Design Expert*

**Nourrigat Elodie** | FAV Champ Libre, Montpellier

*Urban-Landscape Design Expert*

**Rossi Judith** | FAV Champ Libre, Montpellier

*Event co-design Expert*

**PARTICIPANT LIST**

1.	Martina Alia	Italy	Designer	28.	Maria L. Di Francia	Italy	Event Designer
2.	Michele Alloro	Italy	Product Designer	29.	Simone Elemenzi	Italy	Designer
3.	Lorenzo Amelii	Italy	Event Designer	30.	Shanti Escriva	France	Architect, Atelier Amaé
4.	Francesca Armanino	Italy	Event Designer	31.	Francesca Falabella	Italy	Event Designer
5.	Marta Ascheri	Italy	Designer	32.	Sofia Ferraro	Italy	Scenographer
6.	Nadia Baji	Albania	Graphic Designer	33.	Alexia Formica	Italy	Event Designer
7.	Alessia Bergaglio	Italy	Designer	34.	Vincenzo Galtieri	Italy	Designer
8.	Marco Bernat	Italy	Product Designer	35.	Alice Gasparri	Italy	Designer
9.	Alessia Bonacci	Italy	Designer	36.	Sofia Genesin	Italy	Designer
10.	Enrica Bonomo	Italy	Designer	37.	Ludovica Gentili	Italy	Event Designer
11.	Veronica Bracco	Italy	Designer	38.	Morgan Girelli	Italy	Designer
12.	Marianna Bruzzone	Italy	Product Designer	39.	Denise E. Goga	Italy	Designer
13.	Filippo Calderoni	Italy	Event Designer	40.	Maria G. Golino	Italy	Event Designer
14.	Valeria Camperi	Italy	Designer	41.	Riccardo Gorza	Italy	Graphic Designer
15.	Alessia Capetta	Italy	Designer	42.	Giorgia Grasso	Italy	Product Designer
16.	Pietro Carena	Italy	Event Designer	43.	Gebru H. Aman	Iran	Designer
17.	Desireè Carrieri	Italy	Designer	44.	Dario Latrofa	France	Architect, Atelier Amaé
18.	Federica Casu	Italy	Designer	45.	Nicole Lomuscio	Italy	Designer
19.	Federico Celia	Italy	Designer	46.	Serena Macciò	Italy	Product Designer
20.	Claudio Cervetto	Italy	Designer	47.	Maria V. Marino	Italy	Product Designer
21.	Cecilia Cipollini	Italy	Product Designer	48.	Marta Mazzarello	Italy	Designer
22.	Sonia Cirronis	Italy	Designer	49.	Federica Miccoli	Italy	Event Designer
23.	Simone Clemenzi	Italy	Product Designer	50.	Ginevra Mignano	Italy	Designer
24.	Giacomo Costigliolo	Italy	Event Designer	51.	Daniele Mulas	Italy	Event Designer
25.	Francesca D'Ascenzo	Italy	Designer	52.	Daniel Nannini	Italy	Product Designer
26.	Sarah A. Dastgerdi	Iran	Designer	53.	Gabriel Oddone	Italy	Graphic Designer
27.	Giovanni D'Erba	Italy	Graphic Designer	54.	Alessia Olivieri	Italy	Event Designer
				55.	Alessia Orlandi	Italy	Product Designer
				56.	Illaria Pagano	Italy	Designer

- 57. Alessia Passantino Italy Designer
- 58. Giorgia Pezzi Italy Scenographer
- 59. Francesco Pillepich Italy Product Designer
- 60. Andrea Pistone Italy Scenographer
- 61. Giulia Ragno Italy Scenographer
- 62. Ludovica Rebolino Italy Event Designer
- 63. Laura Righini Italy Scenographer
- 64. Lorenzo Sacco Italy Event Designer
- 65. Giulia Salaris Italy Product Designer
- 66. Eleonora Schella Italy Designer
- 67. R mi Sghedoni France Architect, Atelier Ama 
- 68. Aroldo Silvestri Italy Graphic Designer
- 69. Alina Sinchuk Ukraine Designer
- 70. Alessia Stentella Italy Designer
- 71. Arianna Tarditi Italy Graphic Designer
- 72. Aurora Tenca Italy Product Designer
- 73. Fabio Testa Italy Graphic Designer
- 74. Marjeta Thani Albania Designer
- 75. Syria Vannini Italy Graphic Designer
- 76. Francesca Vernazza Italy Designer
- 77. Haoqi Xu China Product Designer
- 78. Elisa Xu Jia China Product Designer
- 79. Yumeng Xie China Designer
- 80. Vanessa Zuffada Italy Designer





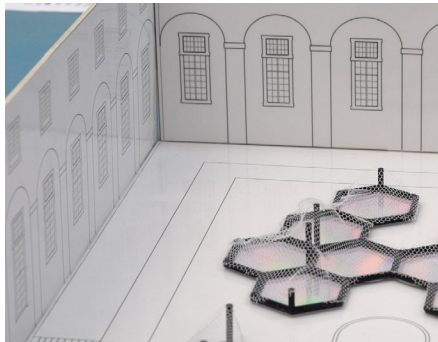



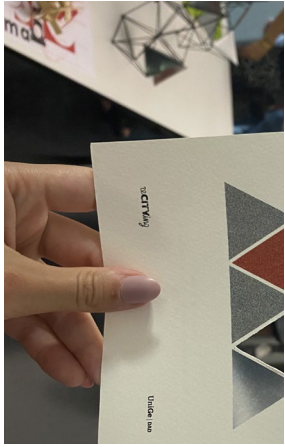







#### **External Experts**

Marco Sinesi \_ ASP Emanuele Brignole;  
Annamaria De Marini \_ ASP Emanuele Brignole;  
Carlo Sciaccaluga \_ Stage director & Teatro Nazionale Genova;  
Guido Fiorato \_ Accademia Ligustica Belle Arti Genova;  
Anna Varaldo \_ Accademia Ligustica Belle Arti Genova;  
Marc Aureli Santos \_ Ajuntament de Barcelona;  
Lisetta Buccellato \_ Scenographer & Costume designer, Paris

#### **ReCITYing Partners**

Manuel Gausa \_ PI ReCITYing - UniGE-DAD, Genova;  
Emanuele Sommariva \_ UniGE-DAD, Genova;  
Nicola Valentino Canessa \_ UniGE-DAD, Genova;  
Silvia Pericu \_ UniGE-DAD, Genova;  
Chiara Olivastrì \_ UniGE-DAD, Genova;  
Giorgia Tucci \_ UniGE-DAD, Genova;  
Jörg Schröder \_ LUH, Hannover;  
Federica Scaffidi \_ LUH, Hannover;  
Willy Müller \_ IAAC, Barcelona;  
Laura Guimarães \_ IAAC, Barcelona;  
Simona Vidmar \_ UGM, Maribor;  
Živa Kleindienst \_ UGM, Maribor;  
Elodie Nourrigat \_ Champ Libre, Montpellier;  
Judith Rossi \_ Champ Libre, Montpellier

#### **WS Tutors**

Chiara Centanaro \_ UniGE-DAD, Genova;  
Federica Delprino \_ UniGE-DAD, Genova;  
Stella Femke Rigo \_ UniGE-DAD, Genova;  
Chiara Maresca \_ UniGE-DAD, Genova;  
Giovanna Tagliasco \_ UniGE-DAD, Genova;  
Omar Tonella \_ UniGE-DAD, Genova



**Barcelona  
Workshop  
09-11.10.2024**

Parc Agrari del  
Baix Llobregat

**reCITYing**  
**Barcelona Workshop**  
**Creative Europe Programme**  
**(CREA-CULT-2023-COOP)**

**2024-2028 cofunded by the European Union**

Partners:

Genoa Unige Università di Genova  
 Barcelona Iaac Institute of Advanced Architecture of Catalonia  
 Hannover LUH Leibniz Universität Hannover  
 Maribor Umetnostna galerija Maribor  
 Montpellier, Association Champ Libre

## Barcelona Workshop

*Institute for Advanced Architecture of Catalonia*

From 9 to 11 October 2024, the Institute for Advanced Architecture of Catalonia (IAAC) and the Parc Agrari del Baix Llobregat will host the Barcelona Creative Workshop of the ReCITYing project. This workshop will bring together students, creatives, international partners and local stakeholders to explore the intersection of architecture, agronomy, and art in reimagining rural spaces through sustainable design and creative recycling. Participants will focus on transforming agricultural by-products, plants, and other materials from the Parc Agrari into artistic architectural installations that address the physical and social underuse of this vital agricultural landscape near Barcelona. The aim is to conceptualize zero-waste installations inspired by the circular economy, transforming discarded materials into meaningful design solutions that celebrate the potential of agricultural spaces.

The workshop will unfold over three days, with immersive work sessions, collective reviews, and a series of lectures and discussions on topics ranging from ecological connectivity to innovative materials, stimulating new ideas and offering creative insights into land art. A full day of hands-on activities will take place in the Parc Agrari, where participants will engage directly with the land by co-planting materials that will be used in the future installation, as well as joining a slow-food barbecue, promoting local, sustainable agricultural products and community interaction. The final day will be dedicated to refining the group proposals before presenting them to an international jury. By merging theory, practice, and community engagement, the Barcelona Workshop will foster new ways to regenerate underused rural spaces and create a lasting impact on the relationship between urban populations and the agricultural landscape.



# Venues



## 01. Parc Agrari del Baix Llobregat

Masia de Can Comas  
Camí del Sorral, s/n  
08820 – El Prat de Llobregat

## 02. IAAC – Institute for Advanced Architecture of Catalonia

C. de Pujades, 102, Sant Martí  
08005 – Barcelona

# Preliminary Activities

## 7 October 2024

11:30–14:30  
**Introduction to Workshop**  
*IAAC (room Itnig 02)*

## 8 October 2024

09:00–19:30  
**Development of Proposals**  
*IAAC (Atelier space)*

# 9 October 2024

09:30–14:30  
**Collective Work Session**  
*IAAC (room Itnig 02)*

Groups' development of proposals & faculty inputs and interactions

14:30–18:30  
**Re-Talks & Re-Debates**  
*IAAC (room Itnig 02)*

14:30–15:00  
**Welcome**  
Speech by Willy Müller

15:00–17:00  
**Re-Talks:**  
15:00–15:30  
Ecological Connectivity,  
by Mathilde Marengo

15:30–16:00  
Living Sculptures,  
by Alejandro Haiek Coll

16:00–16:30  
Sustainable Public Installations,  
by Ana Gallego

16:30–17:00  
Material Innovation & Digital Fabrication,  
by Petra Garajová

17:00–18:30  
**Re-Debates**  
Roundtable discussions among lecturers, international partners and students, moderated by Laura Guimarães

# 10 October 2024

09:00–19:30

## ***Creative Event***

***Parc Agrari del  
Baix Llobregat***

09:00–09:45

### **Transportation to the Parc Agrari**

Bus pick-up at IAAC

09:45–10:30

### **Guided Tour of the Parc Agrari**

Site visit conducted by Eva Ortiz & the Consortium of the Parc Agrari del Baix Llobregat

10:30–14:00

### **Co-planting the Installation\***

Hands-on farming activity, learning how to prepare the soil and distribute seeds from local farmers

*\*participants are advised to wear long pants, protective hats, comfortable shoes, and sunscreen. Water will be provided, but participants should bring their own water bottles.*

14:00–16:30

### **Slow-food Barbecue**

Lunch with vegetables and fruits produced at the Parc Agrari

16:30–18:30

### **Collective Reviews**

Interaction and inputs to groups' projects by International Partners and local stakeholders

18:30–19:30

### **Transportation back to IAAC**

Bus pick-up at the Parc Agrari

# 11 October 2024

09:30–14:30

### **Collective Work Session**

*IAAC (room Space O)*

Groups' development of proposals & finalization of presentations

11:30–13:30

### **ReCITYing Consortium Meeting\***

*IAAC (Fab Meeting Room)*

Internal meeting and brainstorming with project international partners

*\*staff activity, workshop participants are not involved*

14:30–16:30

## ***International Jury***

***IAAC (room Space O)***

### **ReCITYing Workshop International Jury**

Final presentations, jury feedback and selection of winning project

**Website**

[www.recitying.org](http://www.recitying.org)

**Instagram**

[@recitying](https://www.instagram.com/recitying)

## ReCITYing: Rural Regeneration through Creative Design

In contemporary discussions of sustainability, the concept of permanence is often challenged by the growing recognition of the impermanence and adaptability of spaces. Temporary and adaptive reuse offers an alternative to conventional construction by encouraging low impact practices that are responsive to the environment. In the Barcelona case study for ReCITYing, we propose the deployment of a living system that merges design, agriculture, and sustainability to create an architecture that grows, evolves, and sustains itself over time, integrating ecological thinking into the creative process of design.

Ecology is not only a space of criticality and mitigatory or adaptive action but also becomes a vector to drive behaviors within the spaces we inhabit, rethinking who we are designing the planet for and how to shape meaningful and symbiotic living systems. These systems are capable not only of adapting to uncertainties but also of enabling collaborative, reparatory, and regenerative behaviors through spatial design.

With this in mind, we aim to research on how ecological thinking and Land Art can be implemented in peri urban rural regeneration processes, by taking the Parc Agrari del Baix Llobregat, an agricultural park near Barcelona, as a test bed. The challenges that this agricultural landscape faces, such as urban pressure and the gradual abandonment of its spaces, offer a unique opportunity to test the efficiency of creative regeneration through the implementation of landscape art and collaborative ecologies. We explore how this pilot positions itself within this context, studying how the land's resources — plants, by-pro-

ducts, and agricultural waste — can be harnessed to create a self-sustaining system that not only transforms the landscape but also produces materials for an architectural installation, representing an innovative approach to decarbonization by promoting a collaborative and circular economy, reducing waste through ethical and ecological design practices.

Therefore, the Creative Workshop Barcelona introduced young creatives to the potential of agricultural processes to generate sustainable products that ensure that all materials from the land are utilized, generating zero waste and creating fully sustainable products. By developing something from what would otherwise be discarded, participants explored how to create holistic processes that support a circular economy and reinforce the values of sustainability. The exercise encompassed the research and conceptual design of a sustainable small-scale product and a large-scale installation, involving a holistic process that connects creative recycling, sustainability, agriculture, and community engagement, and promotes by-products of farming as a raw material.

As the first phase of the project, this immersive workshop combined theoretical discussions with hands-on experiences, as participants got to spend a day on-site, working directly with the land and the local community, as well as co-planting the materials for the future installation, and participating in a slow-food barbecue.

## CHANGING LANDSCAPES

Aakriti Singh | Aayushi Vasnik | Avi Sharma  
Chanakan Chormai | Rhea Khoury

### SPECIAL MENTION

The “ReCitying” workshop, hosted by IAAC and Parc Agrari del Baix Llobregat, is an initiative launching in October 2024 to explore sustainable design and creative recycling in rural environments. In the first phase, participants will develop proposals for installations that utilize waste materials from the Parc Agrari while integrating crop planting to enhance ecological sustainability. This phase will focus on prioritizing the sustainable reuse of resources, setting the groundwork for the workshop’s broader objectives.

In January 2025, the workshop will shift to its second phase, refining these initial proposals into practical designs. This stage emphasizes processing materials into small products and defining construction techniques, ultimately transforming one selected idea into a full-scale architectural installation. The workshop will culminate in May 2025 with on-site construction at Parc Agrari, involving material gathering, small-scale prototypes, and a public unveiling to engage the local community.

The project also aims to raise awareness about climate change and water conservation. With Catalonia facing significant drought and desertification, the design incorporates modern agricultural methods like hydroponics and aeroponics, which can use up to 90% less water than traditional farming techniques. This focus on water efficiency is crucial in a region grappling with severe water scarcity challenges, highlighting the urgent need for sustainable practices. Through this initiative, the “ReCitying” workshop seeks to foster innovative solutions to address the environmental challenges facing rural communities.

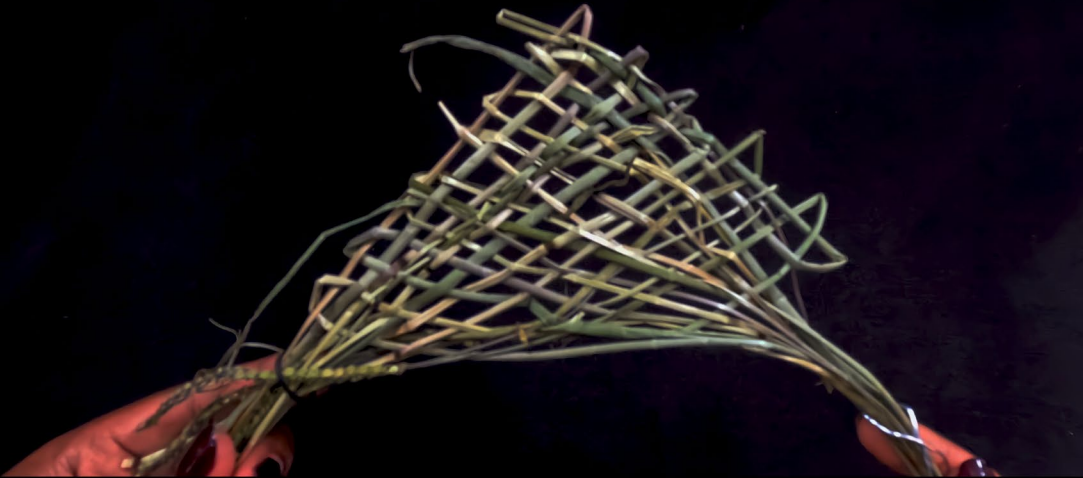
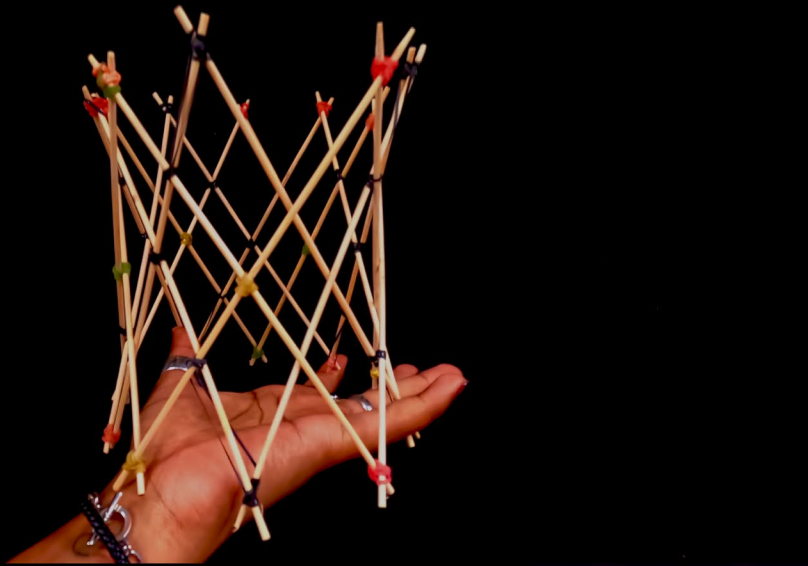

Throughout the workshop, participants have researched vertical farming, hydroponic systems, and innovative water conservation strategies. A key inspiration was the Warka Water Towers project from Africa, which uses nets to capture moisture from the air, a revolutionary method for water collection in arid environments. This concept has been integrated into the installation design to enhance water sustainability.

The initial proposal features two distinct modules: one for water collection and another for plant cultivation, emphasizing the critical role of water conservation in agriculture. A more complex second proposal combines both functions into a single module, representing these essential systems cohesively.

For construction materials, the team will use willow sticks as the primary structural components and barley stalks for water collection nets. Additionally, plant waste will provide a carbon source for the crops within the modules. To optimize water retention, a hydrophobic layer made from biodegradable materials will be developed, showcasing the potential of bioplastics in sustainable design. This innovative biomaterial will support both water collection and plant growth, enhancing the installation's functionality.

The dual-layered design features barley nets for water collection and a biomaterial layer for plant cultivation, improving efficiency and sustainability. By engaging local communities, "ReCitying" aims to foster awareness and promote innovative agricultural practices that address urgent challenges like climate change and resource scarcity, connecting creative sustainability with the needs of rural environments.

Design Development

Vertical Agriculture System

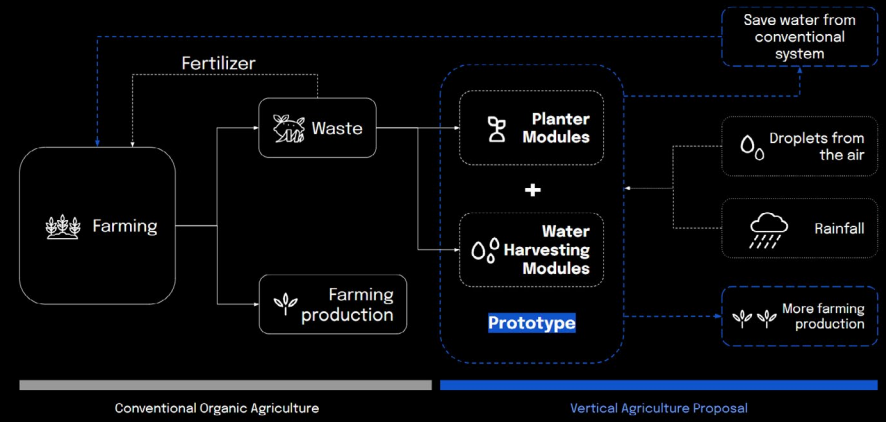

Overall module designs

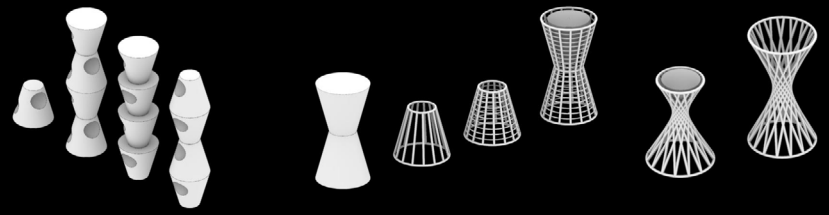

Ecosystem

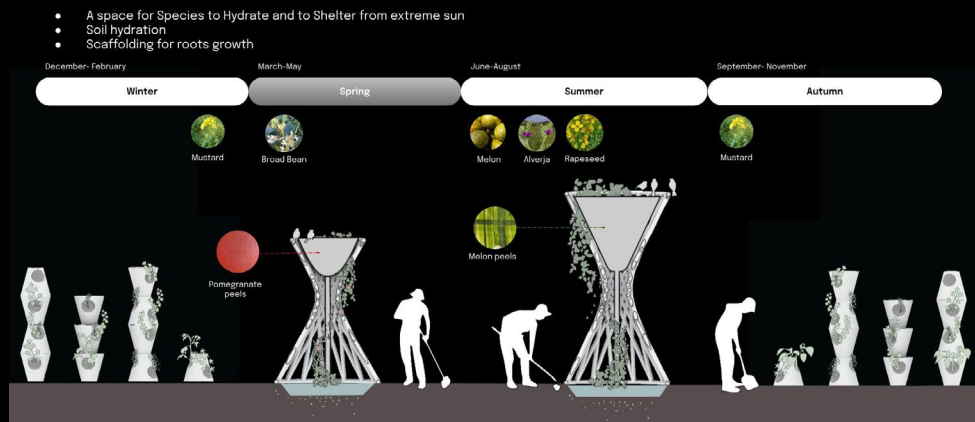



## WEAVING HABITATS

117

Chidubem Ude | Cheng Hen Chen |  
Devanshi Jagota | Ekaterina Starovoitova |  
Juan Camilo Giraldo

### SPECIAL MENTION

Parc Agrari del Baix Llobregat (PABLL) is an agricultural park situated within the metropolitan area of Barcelona, Spain, spanning approximately 3,500 hectares. Around 65% of the area is dedicated to agriculture, while 25% is preserved as natural space. This diverse environment supports a wide range of human stakeholders, including farmers, producers, consumers, and local residents, as well as non-human participants such as fruits, vegetables, birds, bees, butterflies, and over 300 other animal species.

The primary goal of the project was to develop a product that could be used by all stakeholders—both human and non-human—within the PABLL agricultural park, while also embodying the sustainable practices integral to the farmers' approach. Success was measured by focusing on these key objectives:

1. Minimizing harvest waste by repurposing by-products into a fully biodegradable material,
2. Designing a versatile structure that can be scaled and adapted to different uses, and
3. Creating habitats to support the many species essential to the farming ecosystem

The envisioned product is meant to be highly adaptable—starting as a packaging and display solution for farmers at the market and scaling into a larger installation. It was important to create something that customers could easily associate with the farmers' brand, while also ensuring that the market display represented and symbolized the broader activities happening on the farm. The goal is for these products showcased at the market to inspire people to visit the farm, despite its location being away from residential areas.

The installation draws inspiration from the geometric DNA of the stakeholders' habitat, with a lattice grid structure as its core identity. Construction materials are sourced from plant residues cultivated during the soil fallow period, including Barley, Alverja, Broadbean, Mustard, and Rapeseed. **Barley**, chosen for its high cellulose (40–45%) and hemicellulose (25–30%) content, serves as the main material due to its strength. Residue from **Alverja** and **Broadbean**, rich in protein, act as a binder, while **Mustard** and **Rapeseed** contribute durability and water resistance through their oil content.

The process begins by arranging hay in long, aligned strands to form the central framework. A finely chopped binding mixture of Alverja, Broadbean, Mustard, and Rapeseed residues is then prepared, with the option of adding plant-based resin or starch adhesive for improved cohesion. The hay is coated with this mixture, shaped into **rod-like forms**, and **twisted to create added tension**, resulting in rods of varying densities and strengths.

These shaped rods are then dried naturally or with low heat, followed by a curing process for hardening. The final structure, inspired by the Shukhov tower, is assembled to ensure stability while minimizing the need for external reinforcements. The rods are versatile, capable of being crafted into objects as small as cups, beehives, fruit baskets, or chairs, and scaled up to form larger installations, such as pavilions.

The pavilion design ensures that the ground level is accessible for humans and small animals, the mid-level provides habitats for insects, and the topmost layer is reserved for birds. The scalability of the structure is determined by the availability of materials post-harvest, allowing the final form to evolve organically in line with the viability of agricultural processes.

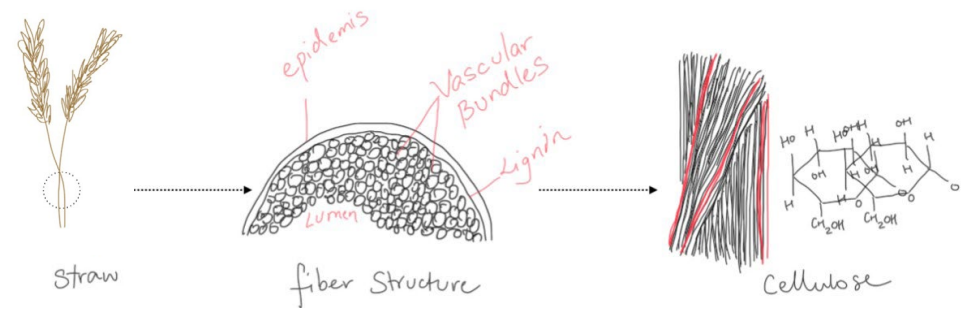

## CUBIERRA

Nupur Sircar | Siddharth Nambiar | Lais Margiori  
| Keerthana Devaraj | Naji Altala | Neyla Coronel |  
Aleksandra Piotrowska

### SPECIAL MENTION

The project draws inspiration from nature and how nature regulates the cycle of life. It is a fact that earth generates and earth dispose, and it is true in the case of plants and crops. In this project we take the idea of decay to help farmers of Parc Agrari de Baix Llobregat make the soil richer with the changing climatic patterns of Catalunya. Soil is the single-most element that nurtures these life processes of plants and crops.

CubierRa, the root cover made from Barley straw and Alverja (pea plant) residues, is an innovative, sustainable solution designed to protect soil, conserve water, and enrich agricultural ecosystems. The product is woven using the vernacular craft of Catalan weaving using crop residues.

Barley straw, known for its durability and slow decomposition, creates a strong and long-lasting mulch that shields the soil from erosion during heavy rains, especially in climates like Barcelona's where intense rainfall alternates with periods of drought. This straw effectively retains moisture, reducing the need for frequent irrigation and preventing water evaporation during dry seasons. Alverja, a nitrogen-fixing legume, brings an additional benefit to the root cover. Together, Barley straw and Alverja residues provide a multifunctional organic cover that not only protects the soil but also fosters a healthier growing environment, promoting sustainability through a zero-waste farming cycle where agricultural waste is repurposed to regenerate the land.

CubierRa has been designed such that the form of the product can be altered based on the plant requirements.

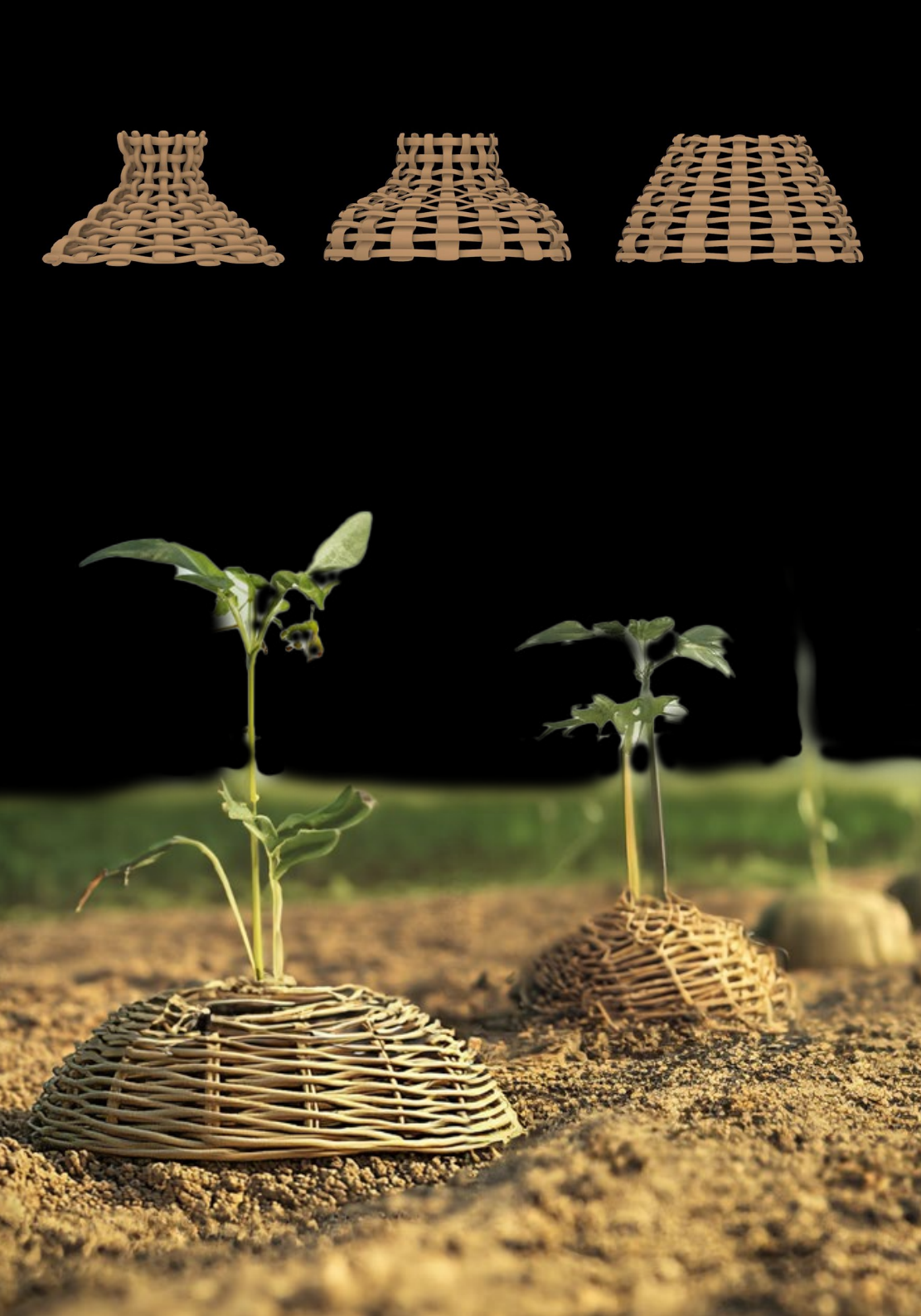

These root covers are intricately handwoven using agricultural waste through the traditional Catalan weaving style. Participants—whether local residents, school children, or visitors—are invited to join in small workshops, fostering a deeper connection to the land and sustainable farming practices. By contributing to the creation of these woven materials, participants are not just learning about organic farming but are also engaging in creative, hands-on work that connects them with nature.

The adaptability of these organic structures is another key innovation. Modular and scalable, the covers can be vertically stacked and incorporated into larger frameworks, evolving into interactive living installations where flowers bloom and insects thrive. These installations are not just functional but also visually striking, becoming part of the natural landscape while inviting the community to participate in their upkeep and growth. The participatory aspect extends even further—locals are encouraged to help build and contribute towards the installations, fostering a sense of belonging and pride in their environment. By allowing individuals to contribute to these projects, CubeirRa promotes a deeper understanding of the recyclability of materials and the importance of sustainability in our modern world.

With its focus on community-driven innovation and the replicability of its designs, the CubeirRa Installation looks to capture the imaginations of both children and adults. Expanding reach, out into the educational networks, fun and engaging activities for school kids in the farms will foster curiosity and interest in the general lifestyle of farming in itself. The project not only educates but also encourages creativity, fostering a shared sense of responsibility for the environment and promoting the idea that small, local actions can have a lasting, positive impact on the world.

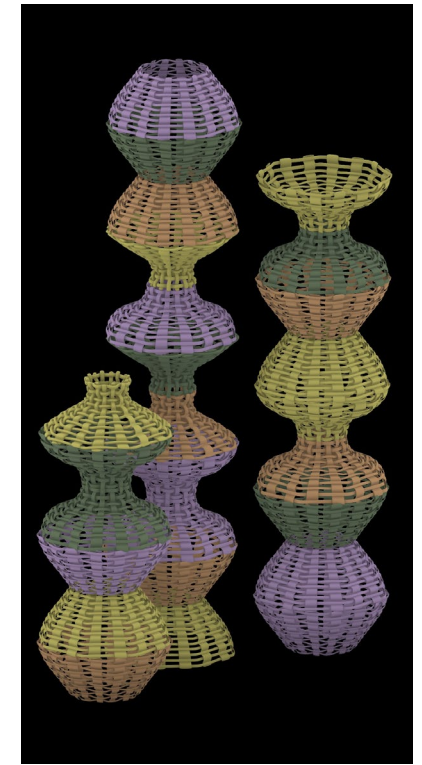
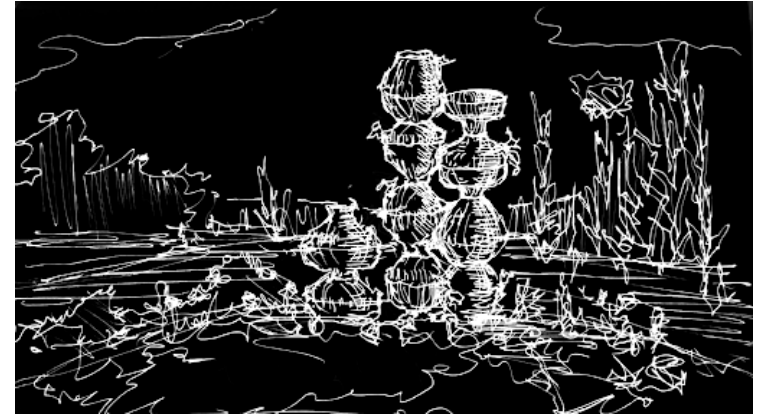



Maria Luiza Gomes Torres, Soham Bhanushali, Raul Winkelmann, Sebastian Raj, Naveen Maria Fleming

**SPECIAL MENTION**

The week-long workshop at Parc Agrari aimed to address the challenges the area faces due to urban development pressures and climate change. As a vital agricultural zone on the outskirts of Barcelona, Parc Agrari has been threatened by real estate developments and renewable energy projects like solar fields. This growing pressure jeopardizes the livelihoods of farmers and the sustainability of agricultural practices. To counter these challenges, the local municipality and consortium overseeing the park recognized the need for sustainable solutions to protect the land, enhance the local economy, and improve farming in the face of external pressures.

During the workshop, students and faculty members interviewed local farmers to better understand their daily challenges. These interviews covered key aspects of farming in Parc Agrari, including crop-related issues, waste management, the effects of climate change, and ways to strengthen the local economy. One critical concern was the decline in pollinator species, particularly bees, which are essential for pollinating crops. The global decline in pollinators is significantly affecting crop yields in Parc Agrari, making it a priority issue to ensure sustainable farming in the area.

To address this, workshop participants researched plant species that could attract pollinators and thrive in Parc Agrari's climate. After identifying suitable species, they planted them in unused soil, with the goal of observing their growth over the next year and assessing their impact on pollinator populations and crop yields. Another key finding from the interviews was the waste generated during farming and harvesting. Farmers revealed that 10% to 30% of fruits and vegetables do not meet supermarket standards due to imperfections, resulting in large amounts of waste, especially from husks of pumpkins, melons, and watermelons.

To tackle both the pollinator decline and agricultural waste, the workshop proposed an innovative solution using pumpkin husks, which are abundant year-round. The participants experimented with using dried pumpkin husks as molds to create biodegradable pots for planting pollinator-friendly species. These pots, made from locally sourced clay and ground bark chips, attract pollinators and eventually decompose, enriching the soil's nitrogen cycle. This sustainable use of waste addresses two key issues—pollinator decline and the underutilization of farm waste.

The workshop also recognized that farmers are increasingly facing extreme weather conditions like heat, wind, and rain, which are exacerbated by climate change. To help farmers adapt, the participants proposed a Climate Shelter next to the crops. The shelter would protect crops from harsh weather, provide a space for educating the local community about sustainable farming, and generate income through workshops on planting and harvesting. The shelter's design incorporated locally sourced materials such as pumpkin husks, clay, and bark chips, which were used to create shading systems and partition walls that also function as living walls to attract pollinators and support crop growth.

Additionally, the workshop explored scalable systems, such as interlocking pumpkin pots and bioplastic screens made from imperfect fruit waste. These products could be sold to enhance the local economy while also supporting ecological goals. By focusing on sustainable design and community-driven solutions, the workshop laid the groundwork for long-term sustainability in Parc Agrari, addressing both environmental and economic challenges.

In conclusion, the workshop provided innovative solutions for the pressing issues faced by Parc Agrari while creating a foundation for future community projects. Through collaboration with local farmers, the utilization of agricultural waste, and a focus on adapting to climate change, the project demonstrates how sustainable practices can protect valuable agricultural land and strengthen the bond between the community and the environment.

*Pots Low Impact Manufacturing Process*

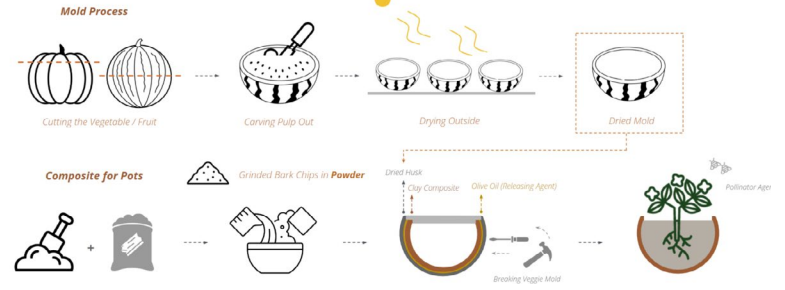

*Design Strategy - COMMUNITY ENGAGEMENT*

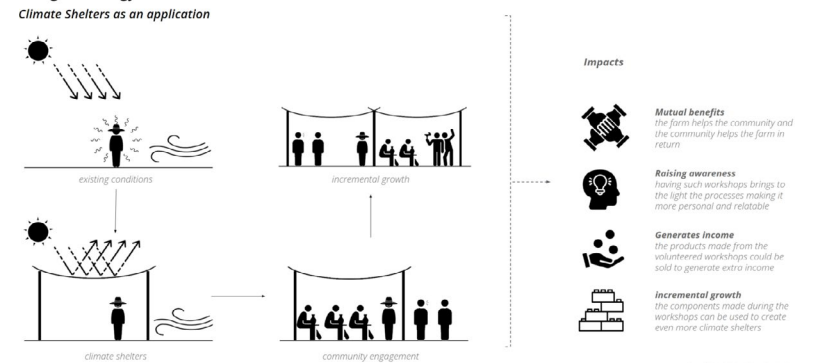



Germarilis Ruiz | Paulina Serra | Sidhardh Suresh |  
Soundouss Aboussekhral Vivek V | Zander Webster

### **SPECIAL MENTION**

This project aims to connect local food producers, consumers, and nature in a symbolic way. The metaphor of a “table” represents unity and sustenance, gathering people across different genders, ages, and social classes. This installation, built from waste materials and invasive plants like *Pontederia Crassipes*, doubles as an ecosystem, attracting species and educating people about the importance of nearby farms. The concept helps farmers struggling with brand identity by offering eco-friendly packaging and leveraging Barcelona’s vegetarian culture to market farm produce. The structure decomposes, returning to the soil as compost after fulfilling its purpose. The installation fosters awareness of the farms near the city, highlighting the need for more visibility of their role in sustainable food production. Through partnerships with local businesses, the project aims to promote the farmers’ brand and encourage consumers to recognize the value of these small, often overlooked, agricultural spaces.

Ultimately, the “Table” serves as a multi-species gathering point where the interaction of natural and human elements can be observed, reminding visitors of the invisible yet vital relationships between food production, consumption, and the surrounding ecosystem.

The concept of Catalunya’s “Table” is to create a metaphorical table that represents a gathering space not only for people but also for various species—humans, animals, insects, and plants—that interact and depend on each other. This “table” grows from the ground using locally available materials such as invasive plants like *Pontederia Crassipes*, which is both a nuisance and a resource in this context.

The design integrates the farm-to-table philosophy, emphasizing the connection between food production and consumption. It's not just a symbolic gathering space for people of different genders, classes, and ages, but also for nature, contributing to a sustainable ecosystem. The pavilion, built from bioplastics and repurposed waste materials, physically attracts insects and small animals, showing how human consumption can work in harmony with natural processes.

The ephemeral nature of the installation is a key aspect of the design, as it eventually decomposes and returns to the soil, completing a natural cycle. This circular process mirrors the life cycle of the plants and animals involved, reinforcing the idea of regenerative design. After the installation is dismantled, its structural elements, like the bioplastic panels made from Pontederia and barley, will be repurposed to create eco-friendly packaging for local produce, which can be distributed in Barcelona's vegetarian restaurants.

For the structure of Catalunya's "Table," we deliberately chose locally available materials to align with the sustainable and regenerative nature of the project. Our material selection was influenced by the specific needs of the site and its ecosystem. One of the primary components is bioplastic made from barley starch, which gives the structure a flexible, fabric-like quality. This bioplastic membrane not only provides structural integrity but also symbolizes the organic, adaptable nature of the installation.

Once the installation is dismantled, the structural panels will be repurposed into eco-friendly packaging for fresh produce from the farm. These branded boxes, created from the same bioplastic and plant fibers used in the installation, will embody the project's sustainable ethos.

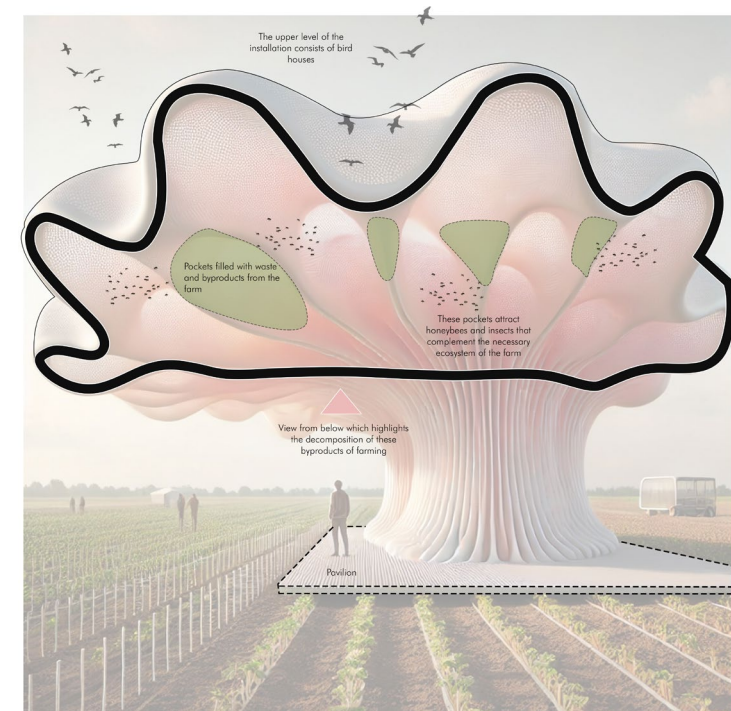
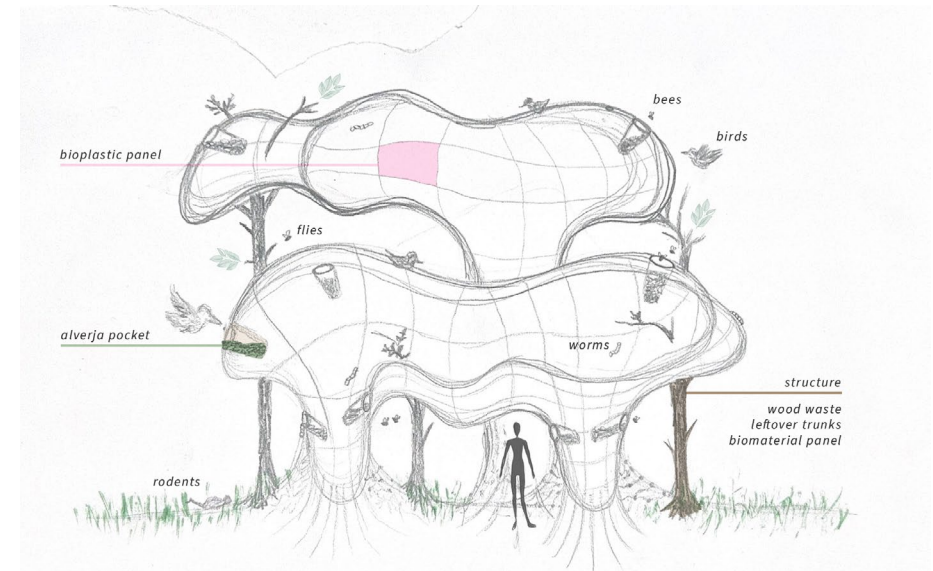

## INSTRUCTOR AND EXPERTS

Institute for Advanced Architecture of Catalonia – IAAC:

**Willy Müller** | ReC IAAC Scientific Coordinator  
*Urban Development Expert*

**Laura Guimarães** | ReC IAAC Project Manager  
*Resilient Urban Design Expert*

**Mathilde Marengo** | ReC IAAC Artistic Director  
*More-than-human Design Expert*

**Ana Gallego** | ReC IAAC Researcher & Designer  
*Public Space Design Expert*

**Isabel Lima** | ReC IAAC Researcher & Designer  
*Community Engagement & Co-design Expert*

with

Petra Garajová | ReC IAAC Tutor

Chiara Farinea | ReC IAAC Jury

## External Experts:

**Alejandro Haiek Coll** | Guest Artist, Umeå University

**Eva Ortiz** | Parc Agrari del Baix Llobregat

**Helena Perxacs Motgé** | Parc Agrari del Baix Llobregat

**Josep Casas** | Parc Agrari del Baix Llobregat

**Josep Parés** | Parc Agrari del Baix Llobregat

## ReCITYing (ReC) Partners:

**Manuel Gausa** | UNIGE, Genoa

*Advanced Urbanism Expert*

**Chiara Olivastrì** | UNIGE, Genoa

*Service design and Communication Expert*

**Chiara Centanaro** | UNIGE, Genoa

*Urban co-design practices expert*

**Jörg Schröder** | LUH, Hannover

*Territorial & Circular Design Expert*

**Federica Scaffidi** | LUH, Hannover

*Urban Recycle Expert*

**Simona Vidmar** | UGM, Maribor

*Art-installation Design Expert*

**Živa Kleindienst** | UGM, Maribor

*Exhibition Design Expert*

**Elodie Nourrigat** | FAV Champ Libre, Montpellier

*Urban-Landscape Design Expert*

**Judith Rossi** | FAV Champ Libre, Montpellier

*Event co-design Expert*

**PARTICIPANT LIST**

1.	Vivek Venkateshappa	IAAC	Architect
2.	Sidhardh Suresh	IAAC	Architect
3.	Soundouss Aboussekhra	IAAC	Architect
4.	Germarilis Ruiz	IAAC	Architect
5.	Laura Guimarães	IAAC	Architect
6.	Eva Ortiz	Parc Agrari	Agricultural Engineer
7.	Willy Müller	IAAC	Architect
8.	Federica Scaffidi	LUH	Lecturer
9.	Jörg Schröder	LUH	Architect
10.	Živa Kleindienst	UGM	Exhibition Coordinator
11.	Chiara Olivastri	UNIGE	Professor
12.	Chiara Centanaro	UNIGE	Researcher
13.	Rebecca Rudolph	Umeå	Architect
14.	Alejandro Haiek Coll	Umeå	Artist & Architect
15.	Simona Vidmar	UGM	Curator
16.	Chiara Farinea	IAAC	Researcher
17.	Isabel Lima	IAAC	Researcher
18.	Naji Altala	IAAC	Architect
19.	Keerthana Reddy	IAAC	Architect
20.	Nupur Sircar	IAAC	Architect
21.	Lais Ioanna Margiori	IAAC	Architect
22.	Siddharth Nambiar	IAAC	Architect
23.	Devanshi Jagota	IAAC	Architect
24.	Chidubem Ekene Ude	IAAC	Environmental Designer
25.	Ekaterina Starovoitova	IAAC	Architect
26.	Juan Camilo Giraldo	IAAC	Architect
27.	Cheng Hen Chen	IAAC	Architect

28.	Manuel Gausa	UNIGE	Architect
29.	Maria Luiza Gomes	IAAC	Designer
30.	Soham Bhanushali	IAAC	Architect
31.	Sebastijanraj Arockiam	IAAC	Architect
32.	Naveen Paulraj	IAAC	Architect
33.	Raul Winkelmann	IAAC	Architect
34.	Mathilde Marengo	IAAC	Researcher
35.	Kevin Matar	IAAC	Architect
36.	Elodie Nourrigat	FAV	Event Designer
37.	Judith Rossi	FAV	Event Designer
38.	Ana Gallego	IAAC	Architect
39.	Rhea Khoury	IAAC	Architect
40.	Aayushi Vasnik	IAAC	Architect
41.	Avi Sharma	IAAC	Architect
42.	Aakriti Singh	IAAC	Architect
43.	Chanakan Chormai	IAAC	Architect
44.	Josep Casas*	Parc Agrari	Farmer
45.	Josep Parés*	Parc Agrari	Farmer
46.	Helena Perxacs Motgé*	Parc Agrari	Geographer
47.	Petra Garajová*	IAAC	Designer

\* didn't sign the attendance list.



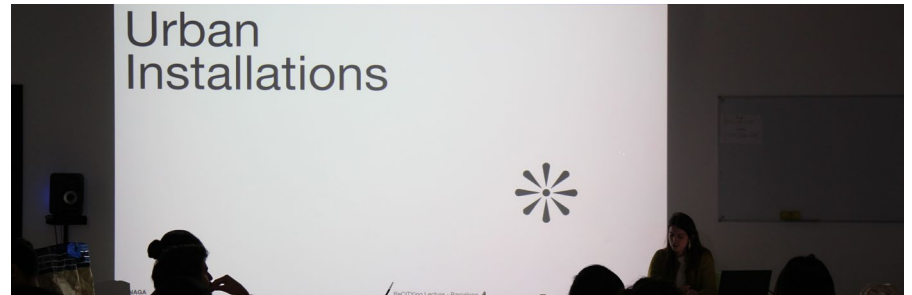





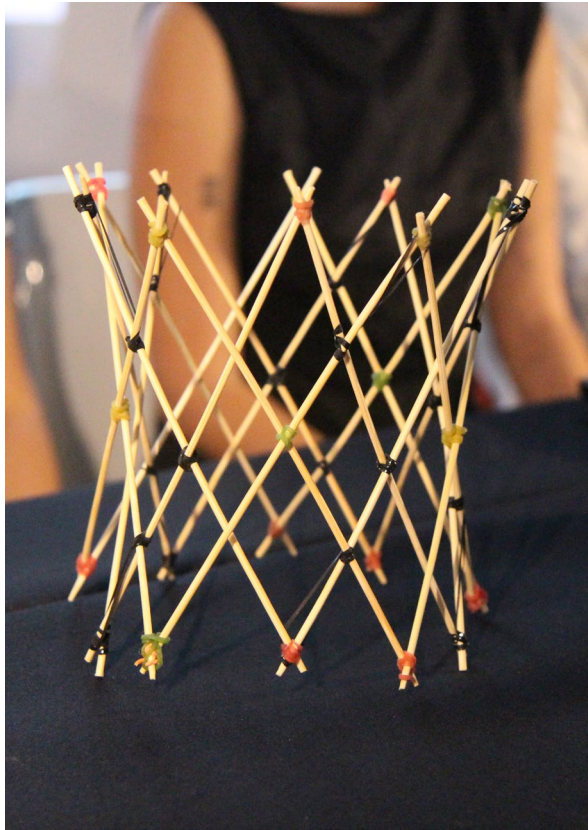





#### **Barcelona Experts & Workshop Tutors**

Willy Müller \_ IAAC, Barcelona  
Laura Guimarães \_ IAAC, Barcelona  
Mathilde Marengo \_ IAAC, Barcelona  
Ana Gallego \_ IAAC, Barcelona  
Isabel Lima \_ IAAC, Barcelona  
Petra Garajová \_ IAAC, Barcelona  
Eva Ortiz \_ Parc Agrari del Baix Llobregat  
Helena Perxacs Motgé \_ Parc Agrari del Baix Llobregat  
Josep Casas \_ Parc Agrari del Baix Llobregat  
Josep Parés \_ Parc Agrari del Baix Llobregat

Alejandro Haiek Coll \_ Guest artist

#### **ReCITYing Partners**

Manuel Gausa \_ PI ReCITYing - UniGE-DAD, Genova;  
Chiara Olivastri \_ UniGE-DAD, Genova;  
Chiara Centanaro \_ UniGE-DAD, Genova;  
Jörg Schröder \_ LUH, Hannover;  
Federica Scaffidi \_ LUH, Hannover;  
Simona Vidmar \_ UGM, Maribor;  
Živa Kleindienst \_ UGM, Maribor;  
Elodie Nourrigat \_ Champ Libre, Montpellier;  
Judith Rossi \_ Champ Libre, Montpellier



**Hannover  
Workshop**  
**04-06.12.2024**  
**Lindener Hafen**

**reCITYing**  
**Barcelona Workshop**  
**Creative Europe Programme**  
**(CREA-CULT-2023-COOP)**

**2024-2028 cofunded by the European Union**

Partners:

Genoa Unige Università di Genova

Barcelona Iaac Institute of Advanced Architecture of Catalonia

Hannover LUH Leibniz Universität Hannover

Maribor Umetnostna galerija Maribor

Montpellier, Association Champ Libre

## Hannover Workshop

*Institute of Urban Design and Planning*

From 4 to 6 December 2024, the Leibniz University Hannover will host the Hannover Creative Workshop focused on music and the urban environment of Lindener Hafen. This dynamic workshop will bring together students, creatives, international partners, and local stakeholders to explore the intersection of urban design, music, and community engagement in shaping a new vision for this evolving area. Participants will develop creative installations and mockups inspired by the acoustic and spatial characteristics of Lindener Hafen, rethinking the use of materials and incorporating sustainability and circularity in design.

The workshop will unfold over three days, featuring immersive work sessions, on-site exploration, and interactive activities at Lindener Hafen. Participants will observe and engage with the space, working hands-on to craft innovative, music-inspired mockups that reflect the unique rhythms and sounds of the area. Lectures and discussions on urban soundscapes, material innovation, and creative engagement will provide inspiration and insights for their projects.

The final day will focus on refining proposals for the international jury and the “awards and feedback event”, showcasing bold, creative solutions for reimagining Lindener Hafen as a vibrant, sustainable urban space. By merging theory, practice, and community involvement, the workshop aims to foster innovative approaches to urban regeneration while emphasizing the cultural and creative potential of music-driven design.



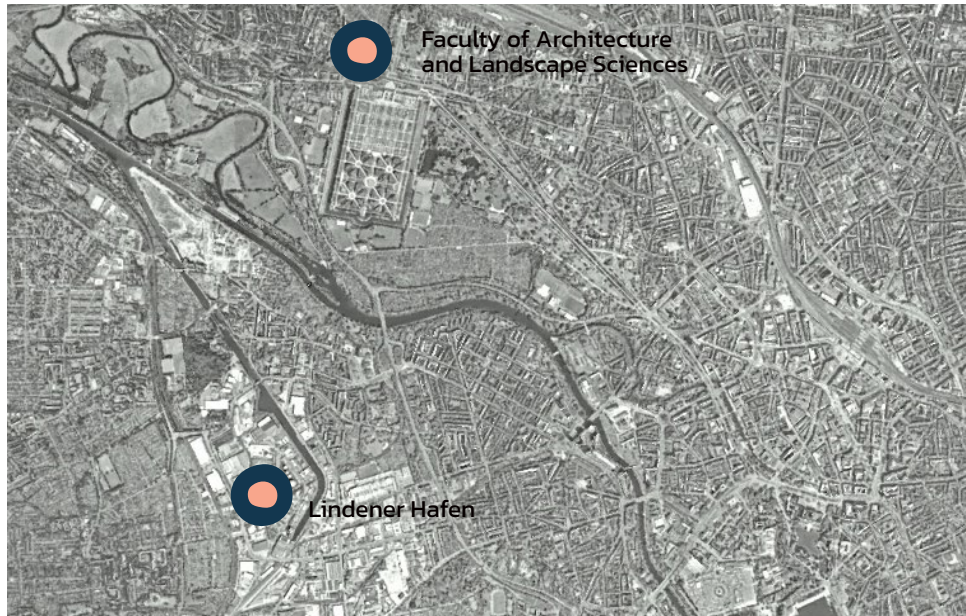

## Preliminary Activities

### 23 October 2024

12:30–14:00  
**Introduction to Workshop**  
 LUH (room A301)

### 30 October 2024

12:30–14:00  
**International references of music installations as urban changers**  
 LUH (room A301)

### 6 November 2024

12:30–14:00  
**Development of Proposals and Pin-up of 1st ideas of installations**  
 LUH (room A301)

### 13 November 2024

12:30–14:00  
**COLLOQUIUM reCITYing**  
**Design and model of the installation (plan with location in Lindener Hafen) + idea of the mockup for Lindener Hafen**  
 LUH (room A301)

### 20 November 2024

12:30–14:00  
**Talks and site visit**  
 LUH (room A301)

## 4 December 2024

16:00–20:00

### Collective Work Session

*Faculty of Architecture and Landscape Sciences, LUH  
 Herrenhäuser Str. 8, 30419 Hannover  
 (room B063)*

16:00–19:30

### Re-Talks & Re-Debates

*LUH (room B063)*

### reCITYing project

16:00–16:30

Welcome by Prof. Jörg Schröder  
 Introduction by Dr. Federica Scaffidi

16:30–17:30

Reports from partners: Genova, Barcelona, Maribor, Montpellier  
 Open discussion

17:30–18:30

reCITYing Talks  
 Riccarda Cappeller  
 Rebekka Wandt  
 Anna Pape  
 Open discussion

### Lindener Hafen and the music

18:30–18:50

Federica Scaffidi  
 Can music act as a trigger for Sustainable Urban Regeneration?

18:50–19:20

Students presentations

19:20–20:00

Discussion round and feedback to students from invited lecturers and international partners

21:00

Social dinner

# 5 December 2024

09:00–19:30

## Creative Event

LUH & Lindener Hafen

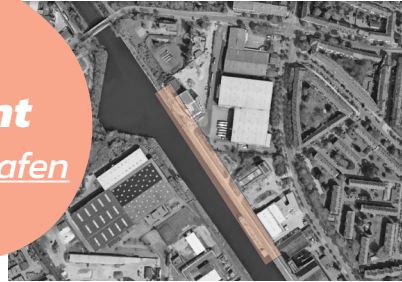

09:00–12:30

### Students' collective work

Collaborative session for students to refine their design ideas and start developing mockups for Lindener Hafen.

13:30–15:30

### Mockups time in Lindener Hafen

Hands-on session working directly on mockups to explore innovative ideas. Envisioning a new future for Lindener Hafen through interactive music-inspired mockups!

15:30–16:00

### Collective Reviews

A feedback session with International Partners and local stakeholders, providing insights and constructive input.

16:00

### Kulturhafen

18:00–20:00

### Christmas Market

Let's take a festive break and enjoy the Christmas Market!

### 20:00 Dinner for project partners



# 6 December 2024

09:00–10:00

### Collective Work Session

LUH B063

Groups' finalisation of presentations & Pin-up

09:00–10:30

### ReCITYing Consortium Meeting \*

LUH, Institute of Urban Design and Planning

Internal meeting and brainstorming with project international partners

*\*staff activity, workshop participants are not involved*

10:30–11:30

### International Jury \*

LUH, Institute of Urban Design and Planning

Pin-up of students work and assessment

*\*staff activity, workshop participants are not involved*

11:30–12:00

## Awards & Feedback

LUH (room B063)

### ReCITYing Workshop International Jury

Final presentations, jury feedback and selection of

Website

[www.recitying.org](http://www.recitying.org)

Instagram

@recitying

## ReCITYing: text

### Music as an Agent of Urban Transformation

In contemporary urban discussions, the intersection of sound, space, and community engagement is emerging as a critical element in sustainable city-making. The concept of permanence is increasingly challenged by dynamic urban transformations that emphasize adaptability and collective experiences. In response, the Hannover Creative Workshop explores the role of music and sound in shaping an evolving, regenerative urban space.

For the ReCITYing initiative, Lindener Hafen serves as a testbed for reimagining spaces through sonic interventions and participatory design. Rather than relying on conventional urban regeneration methods, we propose an approach that integrates sound, architecture, and social interaction to activate underutilized spaces, fostering a vibrant and inclusive urban culture. Music, as a universal language, becomes a medium for placemaking, transforming forgotten industrial spaces into hubs of cultural expression and social connectivity.

Throughout the workshop, participants will engage in hands-on experimentation, creating installations and mockups that respond to the acoustic and spatial character of Lindener Hafen. By integrating principles of circularity, sustainability, and regeneration, the workshop encourages the development of temporary, low-impact structures that reflect the rhythms of the urban space. This initiative does not only explore how sound can enhance the sensory experience of place but also positions music as a driver for community engagement, participatory design, and sustainable urban transformation.

As part of the process, participants will be encouraged to explore the relationship between materiality, sound, and movement, using reclaimed and repurposed materials to create site-responsive installations.

The workshop fosters dialogue between local communities, students, and international experts, generating a collective understanding of how music and design can shape urban life. By experimenting with different spatial configurations, interactive components, and sound-based installations, participants will contribute to a new vision for Lindener Hafen—one that embraces cultural expression, sustainability, and social inclusivity.

By working collectively, participants rethink materiality, sound, and the potential of urban residues to create a regenerative process that connects creative expression with sustainable urban futures. As a culmination of the workshop, proposals are presented to an international jury, where the most innovative and impactful ideas are recognized.

Through this immersive, collaborative process, the Hannover Creative Workshop explores how music-driven urbanism can reframe our understanding of space, public interaction, and regeneration, shaping a city that resonates—both literally and metaphorically—with its inhabitants.

Henry Deutsch | Jacob Kolbe | Nicolas Helm



**HISTORY** Hannover has a long-standing connection to music and was named a UNESCO City of Music in 2014. One of its most notable contributions to music history is through Emil Berliner, the inventor of the gramophone and the vinyl record. His work fundamentally changed how music was experienced, making it accessible beyond live performances.

In Germany, these innovations were distributed by the Deutsche Grammophon Gesellschaft, founded by his brother Joseph Berliner. This marked a significant cultural shift—music became portable and widely available for personal enjoyment. The gramophone laid the groundwork for the ways in which people consume music today, bridging personal and shared listening experiences.

**SHARING** In the present day, music is primarily accessed through smartphones and digital platforms, making it nearly universal. Though music can be a personal experience, it is often something shared with others—at concerts, festivals, or informally between friends. Sharing music creates moments of connection, as individuals introduce each other to new songs and experiences.

Our installation centers around this idea of sharing music. It provides a physical space for people to gather, listen, and share sound together. In doing so, it transforms music from a digital medium back into a shared, tangible experience.

**INSTALLATION** The installation creates a unique space where music can be amplified and experienced collectively. It consists of walls designed to function as analog sound amplifiers, creating an inhabitable speaker. The form pays homage to the gramophone, visually referencing Emil Berliner's innovations while serving as a contemporary tool for sharing sound.

The installation allows users to play music by placing their smartphones into a dedicated slot, where the sound is naturally amplified through the horn-like structure. This creates an intimate listening space where people can sit and share music together.

Additionally, the horn can project sound outward, making it suitable for larger gatherings. Positioned in front of the horn, small concerts, raves, or performances can take place. The horn serves as both an acoustic amplifier and a stage set, activating the surrounding space with sound and visual presence.

**SITE** The location was chosen for its combination of old structures and an open square. The graffiti on nearby surfaces highlights the site's current state—neglected but reappropriated through urban culture. This "urban indicator" reflects the site's potential for renewal.

The installation sits on the foundations of a demolished building, reactivating the space with new purpose. By transforming the site into a cultural and functional gathering point, the project brings back activity and value to Linden Harbor, contributing to its urban quality.

The mockup successfully demonstrated the installation's fun-



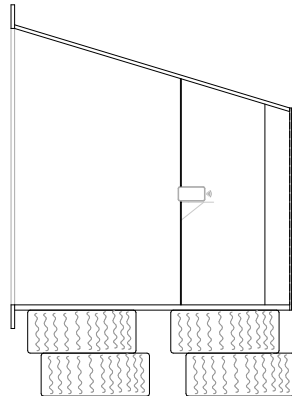
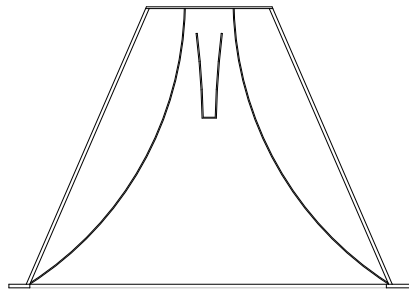
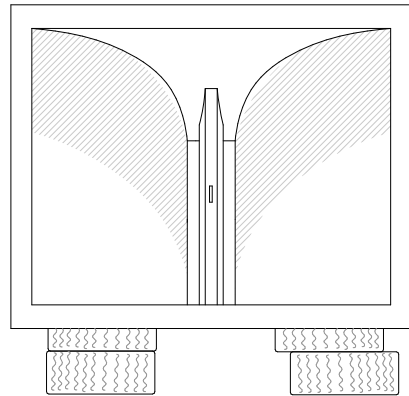

**INSIGHTS** ctionality. The space inside the horn worked well as a seating area, creating an intimate environment for shared listening. It was equally effective when used for collective moments, as the group gathered in front of the horn to experience the amplified sound.

The size of the mockup was limited by the available material dimensions, but it was built as large as possible. Still, we observed that for its use as a bench for two people, the horn could benefit from being slightly larger. This prompted ideas for scaling the installation: smaller horns could act as personal speakers, medium-sized versions as seating areas, and larger versions as performance stages.

Working with a sound engineer in the future could further refine the horn's acoustic properties, enhancing its performance. Exploring different materials would allow us to test variations for sound quality, transport, and durability.

The size of the current installation also posed challenges during transportation. For larger iterations, particularly in contexts like exhibitions in Montpellier, modular construction would be essential. A modular system could allow the horn to be easily transported, assembled, and scaled while maintaining its visual and functional impact.

In conclusion, the installation combines historical references with modern music-sharing culture, creating a physical space that celebrates sound and connection. By reactivating an underused site, it introduces new cultural activity and urban vitality, transforming music into a shared experience once again.

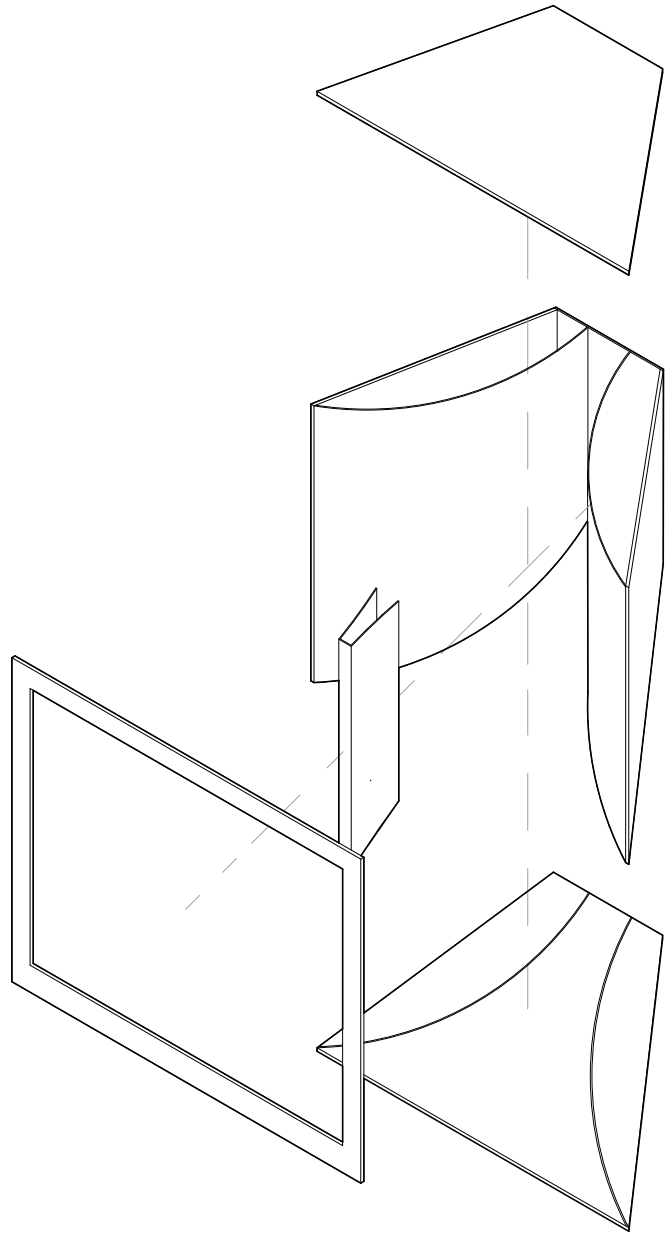

Selma Grein | Laura Kreis

**KLANG KRAFT** Musical Protest as a Light Impulse: Located at the Lindener Hafen, a place steeped in history and resistance, the installation “Klang Kraft” invites you to experience protest in a creative way. Linden, known for its vibrant diversity and long-standing tradition of activism, provides the ideal setting for this project. A neighborhood shaped by protests and the fight for social justice, Linden becomes the starting point for an interactive exploration of the power of collective action. The installation builds on this tradition, transforming it into an artistic experience that encourages participation – through music, light, and individual expression. It consists of a tribune made of Cajons – compact drum boxes played by hand – as well as message and light boxes. Known for its tradition of graffiti and street art, the harbor’s creative and rebellious spirit is reflected in the installation, inviting participants to leave their mark and contribute to the ongoing dialogue.

**CONCEPT** The Energy of Protest: Protests are expressions of resistance, solidarity, and the demand for change. “Klang Kraft” harnesses this energy literally, converting the physical power of participants into electrical energy. Each strike on a Cajon not only creates sound but also powers the installation. The generated energy lights up LED boxes in shifting colors in real time, creating a visual representation of collective strength. But it can also be stored to illuminate the space at night. In the evening, the tribune transforms into a vibrant meeting point, reshaping the atmosphere of the Lindener Hafen. The Path to the Tribüne: Inform and Reflect. An information path leads visitors to the “Klang Kraft” tribune. Along this route, key societal and political issues are highlighted, providing a starting point for reflection and dialogue. Informational displays focus on major protest movements, global challenges, and creative acts of resistance. The path prepares participants for the interactive experience and encourages engagement with pressing topics.

A Space for Voices: Known for its tradition of graffiti and street art, the harbor’s creative and rebellious spirit is reflected in



**PARTICIPATE  
AND CREATE**

the installation, inviting participants to leave their mark to the ongoing dialogue. Boxes are available for painting and sticker art, allowing visitors to leave personal messages and contribute their perspectives. These individual contributions transform “Klang Kraft” into a dynamic, ever-evolving space shaped by the voices of its participants.

**GOAL**

Uniting Message and Expression: “Klang Kraft” offers a playful yet profound engagement with the theme of protest. It explores how energy – emotional, physical, or electrical – can be channeled into something both visible and audible. The combination of sound, light, and personal contributions makes protest tangible, demonstrating how creative expression can offer alternative ways to be heard and seen.

An Invitation to Participate.

“Klang Kraft” is an open space for collaboration and co-creation. It calls on us not only to listen but to actively become part of a movement – loud, visible, and full of energy. Every strike on the Cajons, every painted box, and every message left behind is a step toward a shared message: protest can inspire, connect, and transform, not just demand.



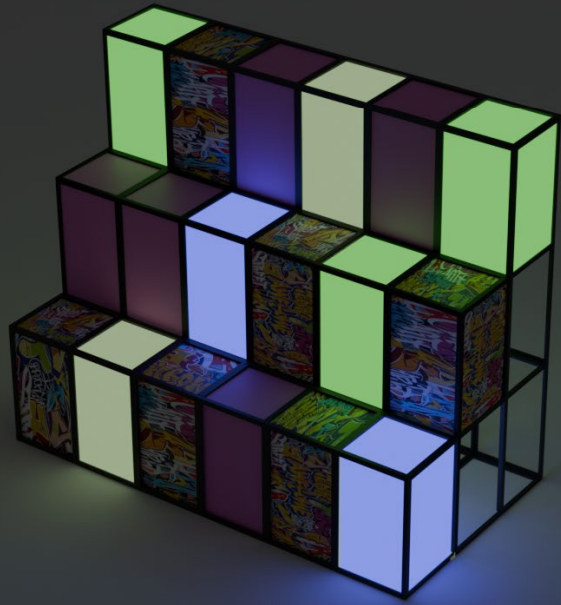

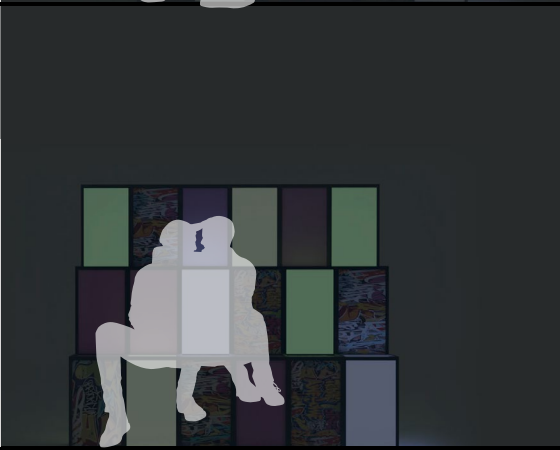
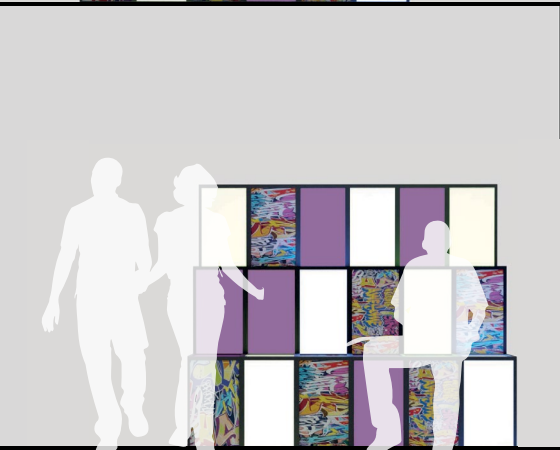
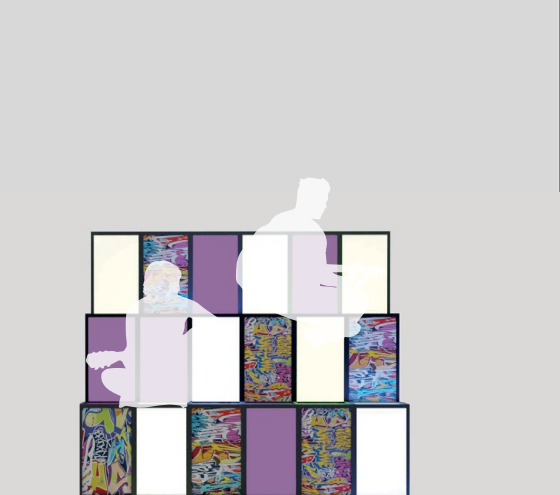

Aassala Klöver | Nina Konken | Nikan Ahmaditaj



**CONCEPT** The Urban Orchest–Art is an art installation that reimagines discarded materials as instruments. This installation highlights the potential of neglected urban spaces and everyday waste, encouraging people to rethink their surroundings by creating music themselves. The play on words in the installation reflects its concept, breaking it down into three dimensions that explain its general intentions: the urban aspect, the orchestra aspect, and the art aspect.

**THE URBAN ASPECT** The Lindener Hafen, as an abandoned and underutilised site, becomes the physical and symbolic canvas for this installation. The urban aspect draws attention to the neglected potential of city spaces, making them places for connection and creativity. By reclaiming the Lindener Hafen, the installation not only activates the space but also invites the city’s residents to reflect on their relationship with their environment.

**THE ORCHESTRA ASPECT** The orchestra aspect symbolises collaboration and collective creativity. Just as a traditional orchestra brings together diverse instruments to create a symphony, this installation unites discarded materials into an ensemble. People engaging with the instruments contribute to this symphony, embodying the idea that each individual has a role in shaping their environment.

So far, we have been able to build four mock-up instruments with materials we found at the university: a tube drum, an amplifier as a metronome, a harp, and a guitar.

Additionally, some of the instruments are partially placed on wheels, a design choice inspired by the trails and tracks at Lindener Hafen. This not only connects to the site's industrial history but also emphasises movement, progress, and transformation, which again aligns with the installation's core message.

**THE ART ASPECT**

The art aspect of the installation emphasises creativity as a tool for connection and reflection. By transforming discarded materials into instruments that produce music, the installation not only creates a unique artistic expression but also brings people together in a shared experience.

The act of making music from waste becomes a symbol of transformation and renewal, encouraging participants to reflect on sustainability and their role in shaping the future. Through interaction with the instruments, people are invited to engage with their environment in new ways—seeing beauty where there was once neglect and recognising the potential for change within their urban spaces and communities.

Ultimately, the art unites sound, space, and people, inspiring collaboration, creativity, and a collective reimagining of what our future can be when we approach it with care and imagination.

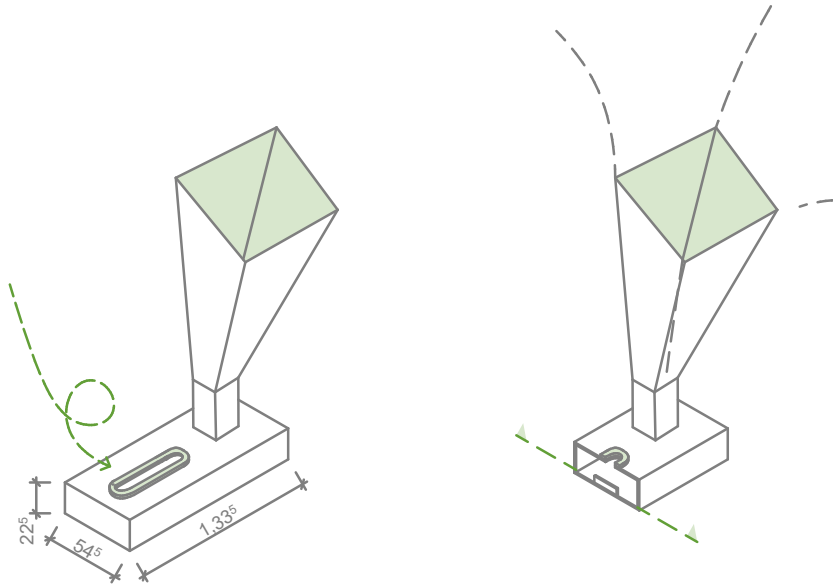
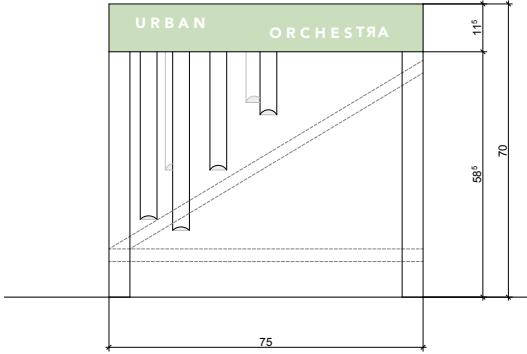
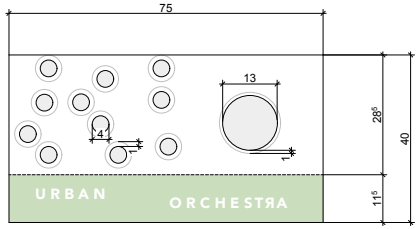

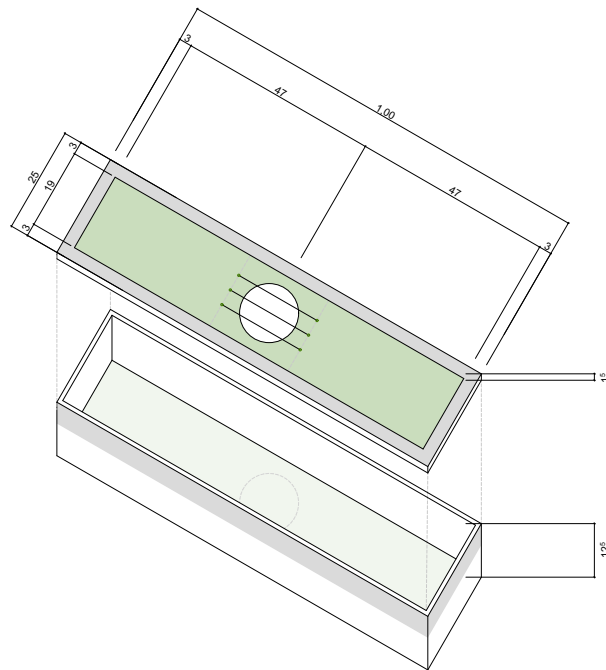
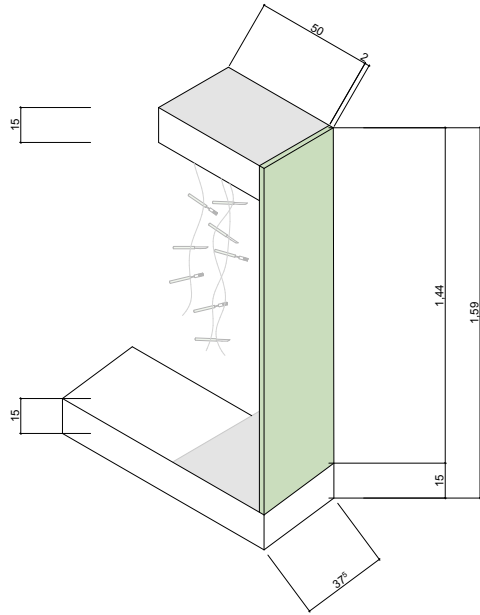

## BOTTLE RESONANCE

Noheir Hussin | Sonja Juutinen | Klaudia Zareba

### INSTALLATION INSPIRED BY THE WATER

In the ReCITYing Workshop: City & Music- course we had an assignment to design a musical installation to Lindener Hafen in Hannover. Throughout the course we worked on the design of our installation and researched the subjects of musical instruments and how musical installations could be used in urban planning. We visited our planning site in Lindener Hafen to be able to design something that fits the place and would emphasize the already existing qualities of Lindener Hafen through our musical installation.

**SITE** Lindener Hafen (eng. Linden Harbor) is a centre of logistics in Hannover. The harbor is centered around 11 km long canal that branches off from Mittellandkanal at Lohnde. Companies from several fields are located in Lindener Hafen from mineral trade to vehicle industry companies. The city of Hannover was named as an UNESCO City of Music in 2014.

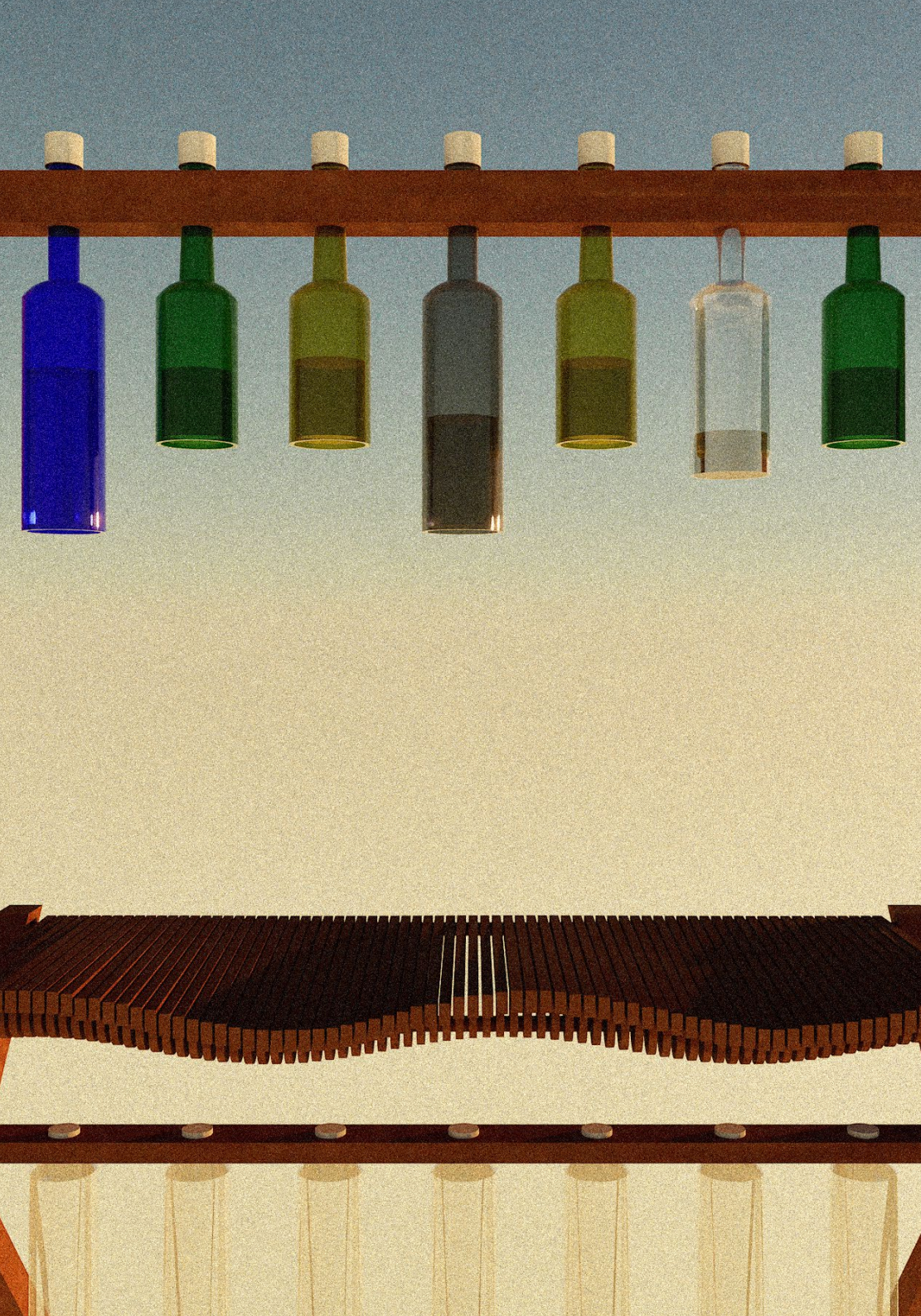

**CONCEPT** Our design solution, Bottle Resonance, is a multifunctional musical installation, that has been inspired by Lindener Hafen's atmosphere: The Bottle Resonance has taken inspiration from the water of the harbor, and we have used both the actual water of the harbor and the water's movement as part of the installation.

The Bottle Resonance uses local recycled glass and plastic bottles, water from Lindener Hafen and wood for the construction of the installation. Multiple installations can be used to create a route of music to Lindener Hafen though to the musical installations lightweight construction and further area planning solutions could be inspired by the musical installation.

In the process of planning the musical installation we have taken into consideration the different users of the installation. The Bottle Resonance provides multiple levels of instruments that can be reached by people of different sizes. The musical installation can be used by both children and adults. The installation can be put together by wooden joints and is therefore easy to take apart or place in another area.

On the ReCITYing Workshop course we learned how to create a Mock Up for our project; we were able to learn a lot about our own installation through constructing it. In the actual installation we consider it would be better to use massive wood in the xylophone as the sound it would make would be more interesting than the one that the wooden parts cut from veneer board make. We would also like to add a bigger lever and stabilizers between the wooden parts so the xylophone, that revolves, would be easier to move. We figured as well that the temperature affects the sound of the plastic bottles with air pressure and it doesn't work as well in a cold environment – therefore we would emphasize the glass bottles in our installation more.



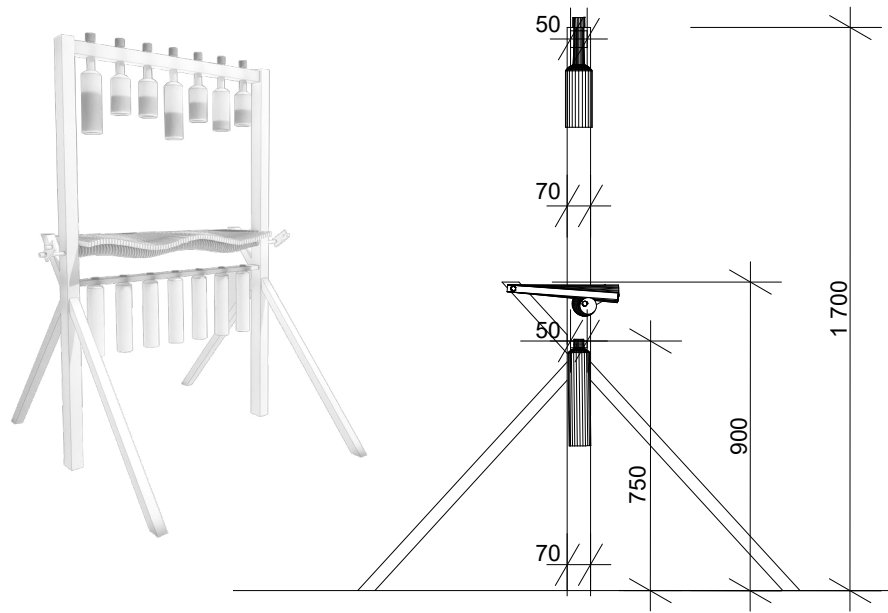
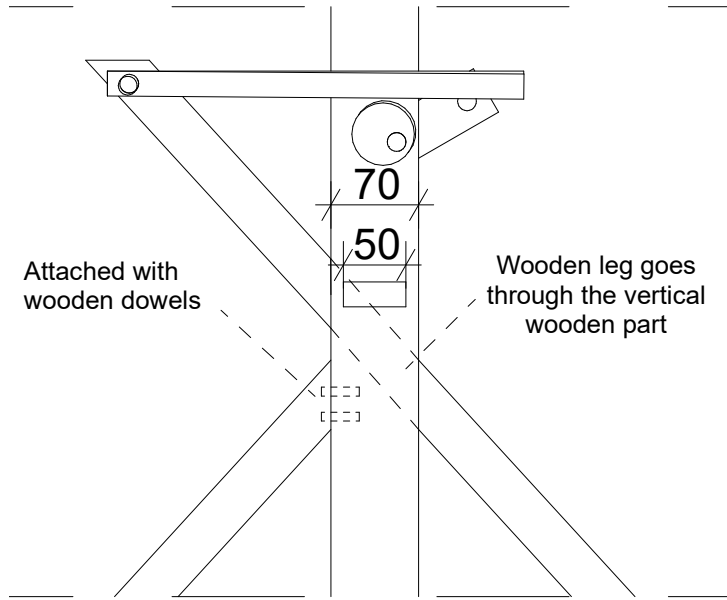

**PARTICIPANT LIST**

1.	Simona Vidmar	UGM	Curator
2.	Ziva Kleindienst	UGM	
3.	Manuel Gausa	UNIGE	Architect
4.	Chiara Olivastri	UNIGE	Professor
5.	Jörg Schröder	LUH	Architect
6.	Federica Scaffidi	LUH	Lecturer
7.	Karoline Engel	LUH	Student assistant
8.	Isabel Lima	IAAC	Researcher
9.	Mathilde Marengo	IAAC	Researcher

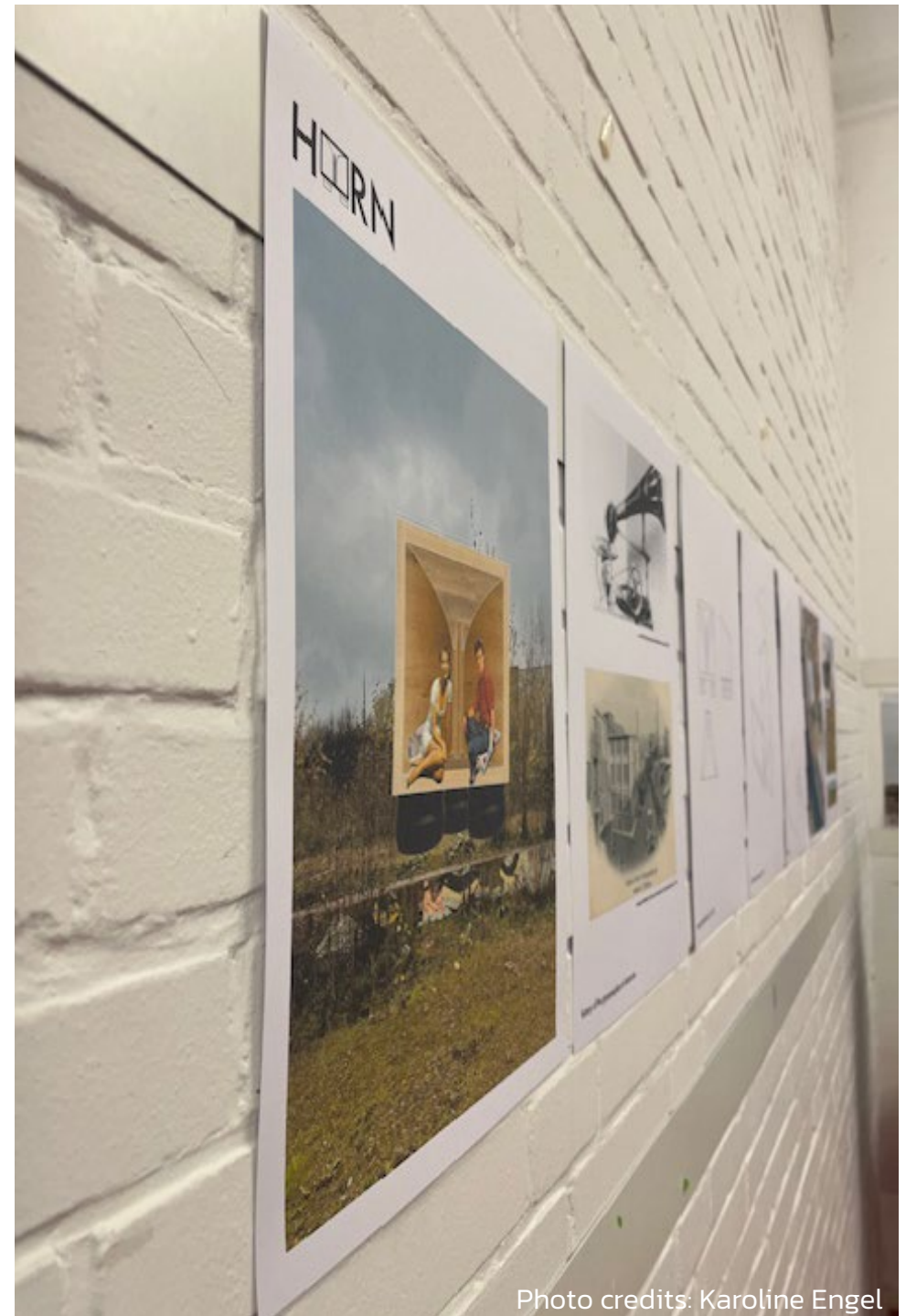

Photo credits: Karoline Engel



Photo credits: Karoline Engel



Photo credits: Karoline Engel



Photo credits: Federica Scaffidi



Photo credits: Federica Scaffidi



Photo credits: Federica Scaffidi



Photo credits: Federica Scaffidi



Photo credits: Federica Scaffidi



Photo credits: Federica Scaffidi



#### **Coordination by**

Jörg Schröder \_ LUH, Hannover  
Federica Scaffidi \_ LUH, Hannover

#### **Steering committee**

Jörg Schröder \_ LUH, Hannover  
Federica Scaffidi \_ LUH, Hannover  
Riccarda Cappeller \_ LUH, Hannover  
Rebekka Wandt \_ LUH, Hannover  
Jackie Williams \_ LUH, Hannover  
Anna Pape \_ LUH, Hannover  
Tutor: Karoline Engel\_LUH, Hannover

#### **ReCITYing Partners**

Manuel Gausa \_ PI ReCITYing – UniGE–DAD, Genova  
Chiara Olivastri \_ UniGE–DAD, Genova  
Chiara Centanaro \_ UniGE–DAD, Genova  
Simona Vidmar \_ UGM, Maribor  
Živa Kleindienst \_ UGM, Maribor  
Elodie Nourrigat \_ Champ Libre, Montpellier  
Judith Rossi \_ Champ Libre, Montpellier  
Laura Guimarães \_ IAAC, Barcelona  
Ana Gallego \_ IAAC, Barcelona

# Maribor Workshop

26.–28. 3. 2025

Račji dvor, Judgement  
Tower & UGM



reCITYing  
 Maribor Workshop  
 Creative Europe Programme  
 (CREA-CULT-2023-COOP)

2024–2028 co-funded by the European Union

Partners:

UniGe - Università di Genova, Genova, Italy

IAAC - Institute of Advanced Architecture of Catalonia, Barcelona, Spain

LUH - Leibniz Universität Hannover, Germany

UGM | Maribor Art Gallery, Slovenia

Association Champ Libre, Montpellier, France

## Venues



**01. Račji dvor & Wagner's House,** Raški dvor 1  
**02. Sodni stolp (Judgement Tower) / Minoriti,** Pristan 8  
**03. UGM | Maribor Art Gallery,** Strossmayerjeva ulica 6

## Preliminary Activities

**15 January –9 March 2025**

**Open Call for architectural and artistic interventions at Račji dvor Mansion**

**12–14 March 2025**

**Open Call / Preselection Process**

*Preselection of the proposals received through the Open Call by the jury members.*

**28 March 2025**

**Project presentation and Kick-Off of Faculty of Architecture's student's seminar**

*Architecture students from the University of Maribor will be studying and testing different theoretical and practical approaches to rethinking the use of the wider Račji dvor area as part of a study seminar in the spring semester. The UGM team will present the site against its historical background, the reCITYing project and project activities, and the programme of the Maribor Workshop.*

## Maribor Workshop

### UGM | Maribor Art Gallery

From 26 to 28 March 2025, the UGM | Maribor Art Gallery hosted the Maribor Creative Workshop, which focused on the reactivation of the Račji dvor Mansion through visual arts. A former Benedictine trading estate, with a thousand-year history, today stands at the crossroads between the utilitarian value of a warehouse and the cultural potential of an urban green zone. In January, UGM launched an open call for temporary architectural and artistic interventions into Račji dvor, the nearby abandoned vernacular Wagner's House, and their surrounding area which has brought forward bold and innovative proposals. The dynamic workshop programme brought together architects, artists, students and other creatives shortlisted through an open call, as well as other experts and professionals, international partners, and local stakeholders, to explore the possibilities of reactivating this exceptional site of cultural heritage.

The workshop unfolded over three days, starting with a series of lectures by internationally renowned architects, artists and urban planners. The lecture series provided the insight into several visionary revitalization projects in Maribor and its surroundings, and theoretical frameworks at the intersection of architecture, visual arts, cultural heritage, urban design, revitalisation, sustainability and ecology.

On the second day, we visited the Račji dvor Mansion, Wagner's House, and the surrounding area and enjoy a guided tour by experts in visual arts, architecture and heritage conservation. We were joined by local stakeholders. After the site visit, we continued with two sessions of presentations of the open call proposals pre-selected by the reCITYing jury members. Individual authors, interdisciplinary collectives or groups presented their proposals, followed by feedback sessions and discussions. By bringing together practice, theory and community engagement, with this workshop our goal was to foster creative interdisciplinary approaches to urban regeneration through visual arts and art.

# Wednesday, 26 March 2025

18:00–20:30

## Rebuilding the City

Sodni stolp (Judgement Tower) / Minoriti, Pristan 8

**A series of presentations of architectural and community projects.**

- 18:00 **Introduction**  
Simona Vidmar Čelik, UGM Director & Stojan Skalicky, Architect
- 18:10 **Challenges and Traps Make Things Interesting**  
Jurij Kobe, Architect and Founder of ATELIERarhitekti
- 18:30 **The City and the River – The Case of Lent**  
Prof. Maruša Zorec, Architect and Founder of Arrea Architecture; Faculty of Architecture, University of Ljubljana
- 18:50 **Dialogue with History**  
David Mišič, Architect and Founder of Styria Arhitektura
- 19:10 **Reconstructing Atmosphere: Urban Design and Phenomenology – The Case of Vojašniški Trg in Maribor**  
Assist. Prof. Rok Žnidaršič, Faculty of Architecture, University of Ljubljana, and Jerneja Fischer Knap, Architects and Co-founders of Medprostor
- 19:30 **Abandoned Quarries: Places of Crime or Spaces of Poetic Imagination**  
Assist. Prof. Gašper Medvešek, Faculty of Architecture, University of Ljubljana
- 19:50 **Activating Spaces and People: Three Examples from My Practice**  
Assist. Prof. Polonca Lovšin, PhD, Architect and Artist, Faculty of Education, University of Primorska

20:30–22:00 **Dinner**

# Thursday, 27 March 2025

9:00–11:00

## **Site Visit & Tour**

Račji dvor, Raški dol 1

Guided tour of Račji dvor, Wagner's House and surroundings by experts in visual arts, architecture and cultural heritage conservation.

12:00–18:30

## **Meet the Creatives**

Sodni stolp (Judgement Tower) / Minoriti, Pristan 8

12:00–14:00

### **Session 1: Short presentations of the open call proposals & jury's feedback**

- 12:00 — Sara Badovinac & Sara Škarica: Cascade Drinking Fountain
- 12:20 — Adam Breznik & Zala Zia Lenárdič: Where the Gaze Lingers, the Future Begins
- 12:40 — Nadej Rešek & Olga Ushakova: The Old Sick Bacchus
- 13:00 — Sanja Halb & Karmen Janžekovič: The Cube
- 13:20 — Matic Kašnik: Visible Silence
- 13:40 — Bor Kračun-Pižmoht & Miha Kramberger & Živa Miklavčič: Tic Tac Toe

14:00–15:00

### **Food & Drinks**

15:00–17:30

### **Session 2: Short presentations of the open call proposals & jury's feedback**

- 15:00 — Kolektiv 96: Culture Node
- 15:20 — Kontra: Plateau
- 15:40 — Žiga Miholič & Maša Perc: Colour Palette of Activity
- 16:00 — Natalie Resch & Anja Zamuda: Reflect
- 16:20 — Sara Divjak & Vid Greif: Let's Go to Račji!
- 16:40 — Mojca Založnik
- 17:00 — Lena Uranjek & Ishak Hadžibajrić: Where Are You Hiding, Račji dvor?

17:30–18:30

### **Jury's meeting**

Najstarejša trta (The Oldest Wine),  
Vojašniška ulica 8

19:00–21:00

### **Dinner**



# Friday, 28 March 2025

9.00–11.00

## **Partners' Meeting**

*UGM | Maribor Art Gallery,  
Strossmayerjeva ulica 6*

11.00–12.00

## **Spekter. 70 Years of the UGM Collection / Guided Tour of the exhibition and UGM premises**

UGM | Maribor Art Gallery,  
Strossmayerjeva 6



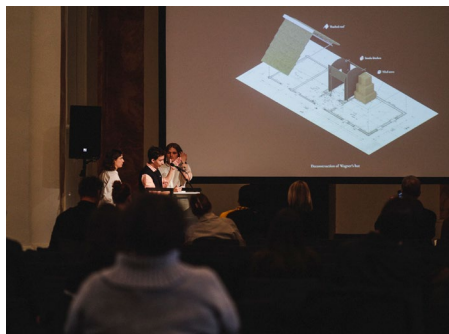

## RE-ACTIVATING CULTURAL HERITAGE THROUGH ARCHITECTURE AND VISUAL ARTS

Visual art and other forms of creativity have a recognised and established role in the reactivation of vacant public and semi-public spaces and architectures. By transforming abandoned, overlooked or vacant spaces of cultural and architectural history into vibrant artistic settings, contemporary visual art revitalizes urban areas—they invite and engage diverse audiences, foster community participation, and ignite conversations about local culture, identity, and shared history. In many cases, such artistic endeavours act as a springboard for broader urban renewal, attracting tourism, encouraging cultural activity, and stimulating economic investment.

Through imaginative and poetic expression, artists, architects and other creatives can reframe and reinterpret various sites, and buildings. In doing so, visual art not only enhances physical surroundings but also strengthens community bonds and reawakens collective memory, breathing new cultural energy into the heart of the city. With projects as *reCITYing*, at UGM we focus on drawing the attention to the importance of the historic building stock and the preservation of cultural heritage in Maribor and its surroundings. With contemporary art, we enter spaces that demand our attention, re-present them to the public, and bring together in dialogue various stakeholders.

Račji dvor, a former Benedictine estate with a thousand-year history and a unique location under the city's wine-growing hills, is today mainly used as an occasional warehouse. On the green edge of the city, the mansion offers a place to reflect on its reactivation and integration back into public life. For doing so, UGM | Maribor Art Gallery launched a call for artistic and architectural interventions inviting students and young

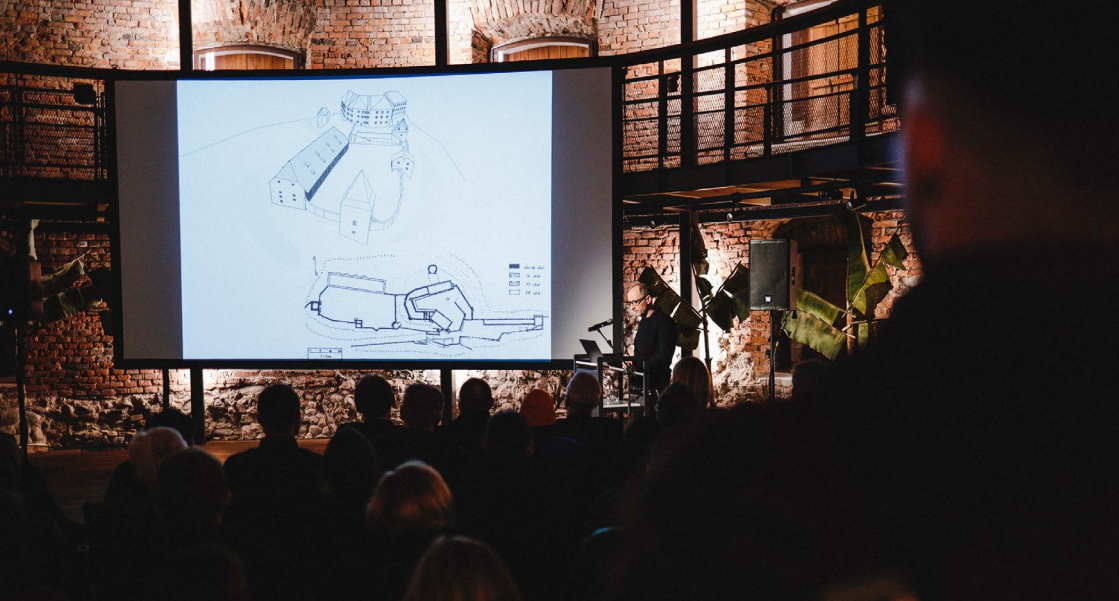

professionals working in the fields of contemporary visual arts, architecture, design, urbanism, visual communications and other creative fields, to propose bold and unique projects for reactivation of Račji Dvor. The open call focused on the Račji dvor and the nearby typical farmhouse from the wine-growing hinterland of Maribor – Wagner's House. The Račji Manor was renovated 30 years ago in the perspective of cultural and economic activity (a museum of viticulture and an open-air museum), but since then it has fallen into disrepair and has been abandoned, staying firmly anchored in the collective memory of Maribor's inhabitants.

Empty spaces of architectural and natural heritage with thousands of years of sediment and many transformations are the building blocks of the rebuilding of the city. In Maribor and beyond, major shifts are taking place in this field. Against this background, a series of short lectures by prominent Slovenian architects and urbanists was conceived with an aim to reveal well-known and lesser-known projects for the reactivation of urban architectures, urban districts and other vacant spaces. Architectural heritage, medieval urban fabric, empty building pits and abandoned quarries can be the scenes of success stories of rebuilding community life and returning spaces to the city and its inhabitants.

A number of creatives working in the fields of visual arts, design and architecture responded to the UGM's open call for temporary art and architecture interventions at Račji dvor, with innovative proposals. Shortlisted architects, artists, students and other creatives present their proposals during an open-to-public series of presentations and discussions. Based on the presentations and discussions, the international jury has awarded **three main prizes** to the following authors and proposals:

**Adam Breznik & Zala Zia Lenárdi:**  
**Where the Gaze Lingers, the Future Begins**

**Lena Uranjek & Ishak Hadžibajrić:**  
**Where Are You Hiding, Račji dvor?**

**Žiga Miholič & Maša Perc:**  
**Colour Palette of Activity**

The jury also decided to select **three special mentions:**

**Matic Kašnik:**  
**Visible Silence**

**Bor Kračun – Pižmoht, Miha Kramberger in Živa Miklavčič:**  
**Tic Tac Toe**

**Mojca Založnik**

In the first phase of the project, this dynamic workshop combined theoretical discussions, examples of successful revitalization projects, and innovative proposals. As the participants got to engage with other professionals, students, and the site itself, the workshop prepared the foundations for the successful development of the second phase of the project – implementation of the selected proposals and installation day in the upcoming autumn months.



## WHERE THE GAZE LINGERS, THE FUTURE BEGINS

Adam Breznik & Zala Zia Lenárdič

### MAIN AWARD

The installation delves into the layered history of the abandoned Račji Dvor estate—a site once imagined with various futures that never materialized. It broadens the conversation to consider similar structures that exist in a kind of suspended state, caught between visibility and invisibility, both physically and within the social imagination. In this context, Derrida's concept of hauntology becomes particularly relevant. Drawing on its linguistic play with "ontology"—the silent "h" in French underscoring its ghostly nuance—it describes something that is present yet ineffable. This mirrors the ways such spaces are experienced: not fully there, yet undeniably felt.

Central to the project is the symbolic act of revealing the building's façade by stripping away a layer of installed thermal insulation—a material metaphor for safety and warmth. This gesture suggests not only exposure but a willingness to confront change, to imagine a new future. Video mapping enhances the transformation of both the mansion itself and the Wagner's House, illuminating their hidden internal structures in the newly revealed areas—spaces that remain physically inaccessible. These specific façade interventions align with original entrance points, linking the estate's exterior with its internal atrium—thresholds where presence and absence intertwine in a spatial paradox.

*The jury concludes that the artists have designed*

*an original architectural installation, both in terms of its content and form, which symbolically reveals the layers of the centuries-old history of the Račje Manor. The visual appeal of the intervention is achieved by the choice of format, form and material, which, in the wider context of the Duck Court and the Wagner House, are convincing, responsive to the architectural space, aesthetically pleasing and clearly communicative. The intervention by Adam Breznik and Zala Zia Lenárdič eloquently combines the principles of visual art and architecture, whose appearance invites reflection on the potential futures of a now degraded architectural heritage.*

### JURY'S FEEDBACK

*Due to the technical, financial and ownership constraints of the Duck Court and the Wagner House, the jury proposes the further development and realisation of the proposed intervention in the Wagner's House, as conceived by the authors in their project proposal. The jury considers that, despite the adaptation, the project retains its basic conceptual premise and makes an important point about the deterioration and neglect of cultural heritage and, consequently, of collective historical memory.*

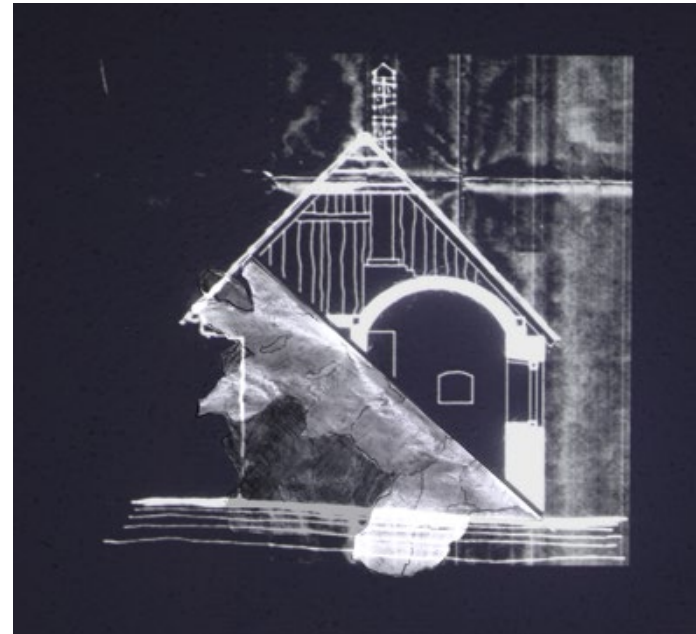
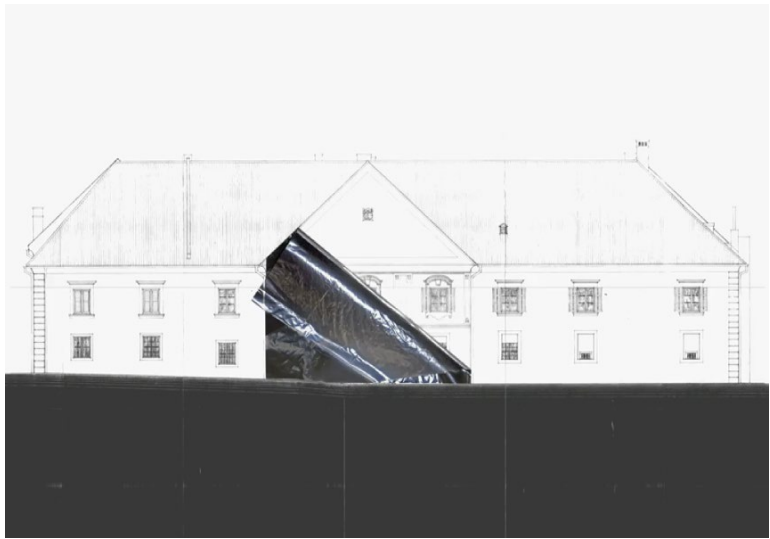
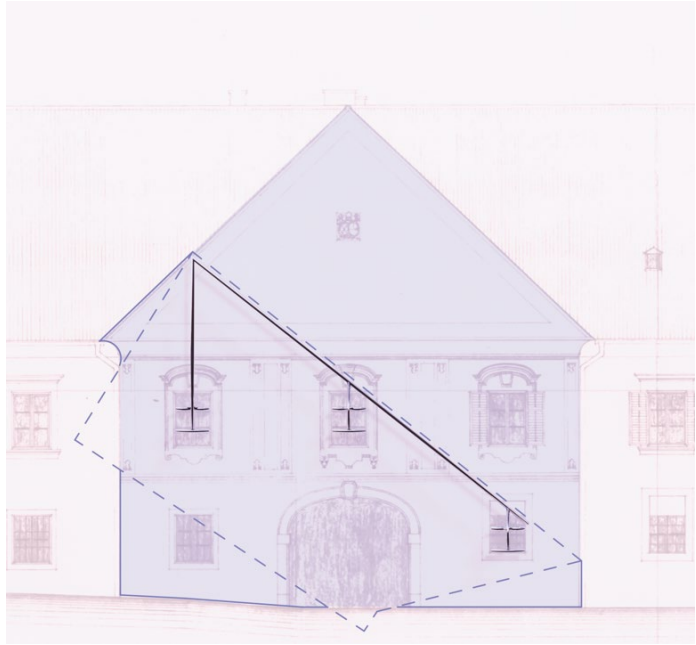

## WHERE ARE YOU HIDING, RAČJI DVOR?

Lena Uranjek & Ishak Hadžibajrić

### MAIN AWARD

The concept emerged from a sense of curiosity and wonder, inspired by the authors' perception of the site's current condition. Though frequently visited by hikers and locals seeking tranquility in nature, the mansion remains little more than a relic—a shadow of its former self. Secluded and inward-facing, it exists in a kind of self-imposed isolation, frozen in time and detached from the present. It hides in plain sight, caught in an endless game of hide-and-seek with no one actively searching. This realisation sparked the project's central idea: to create a connection between the fleeting presence of passersby and the quietly concealed castle—to invite them to become seekers. By deliberately masking what is already obscured, the installation stimulates curiosity, transforming routine walks into playful, immersive experiences.

The intervention centers around the familiar and poetic image of hanging white laundry and children's game of Hide-and-seek. Installed at key locations, the installation encourages exploration and discovery. Acting as both a barriers and tactile guides, the sheets partially obscure views/gazes while drawing visitors in. Decorated with maps, artistic elements, and historical context, they create a living veil around the castle—an engaging interface that dissolves the boundary between visibility and concealment, past and present—ultimately awakening the castle from its silent retreat.

### JURY'S FEEDBACK

*The jury concludes that the artists have designed an original architectural installation, both in terms of its content and form, which symbolically reveals the layers of the centuries-old history of the Račje Manor. The visual appeal of the intervention is achieved by the choice of format, form and material, which, in the wider context of the Duck Court and the Wagner House, are convincing, responsive to the architectural space, aesthetically pleasing and clearly communicative. The intervention by Adam Breznik and Zala Zia Lenárdič eloquently combines the principles of visual art and architecture, whose appearance invites reflection on the potential futures of a now degraded architectural heritage.*

*Due to the technical, financial and ownership constraints of the Duck Court and the Wagner House, the jury proposes the further development and realisation of the proposed intervention in the Wagner's House, as conceived by the authors in their project proposal. The jury considers that, despite the adaptation, the project retains its basic conceptual premise and makes an important point about the deterioration and neglect of cultural heritage and, consequently, of collective historical memory.*



EXECUTION

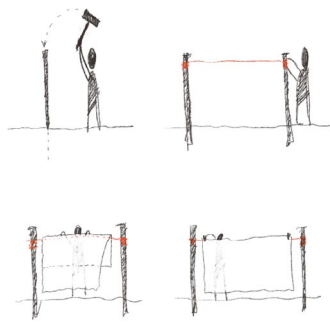

REUSE

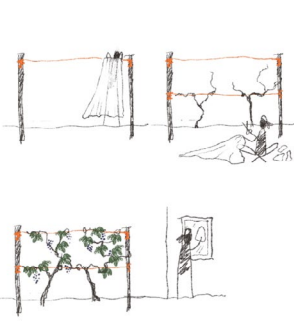

## THE COLOUR PALETTE OF ACTIVITIES

Žiga Miholič & Maša Perc

### MAIN AWARD

The concept of the intervention does not follow the buildings or history of Račji Dvor, but focuses on the surrounding space. It primarily connects to activities that are most common there, such as walking, running, and generally relaxing in nature. The authors decided to shape the space based on activities (relaxing in nature, sports, socialization), while also focusing on the main paths of the passers-by. Result is a new main circular path that no longer passes by the parking lot in front of the manor but goes through the three most beautiful microlocations in the area. Each environment has its own atmosphere and is intended for different activities—sports, art, and relaxation.

Three points are positioned at locations where the most beautiful views open up and where the flow of people is the most condensed. The space has been designed with columns, which are the primary architectural element, and it has been emphasised with primary colors—red, blue, and yellow—so that each point represents a different environment. The first, blue point, is intended for relaxation while reading about art or creating art (drawing on the columns). The sphere of the space is also shaped by a circular arrangement and materiality, with some columns wrapped in mirrors, reflecting the beauty of both art and nature. The second, red point, is placed on the meadow in front of the manor and extends into the area of the concrete plaza. It is intended for the most popular activity, which is sports, with

columns set in a polygonal arrangement that attracts both children and adults. The third, yellow point, is at the end of the route and represents the most beautiful part of the area, offering views of the Pohorje mountains and the lower meadow. Here, the path continues towards

Kalvarija. This point is mainly intended for rest and connects with the surrounding area and the nearby houses through garden plots, which the authors designed, once again as columns = raised beds. The aim is to invite people to pause, engage, and enjoy the beauty of the area. Through this experience, the aim is to foster a deeper appreciation of Račji Dvor and spark ideas for its future potential use.

*The proposal by Žiga Miholič and Maša Perc focuses not only on the architecture and history of Račji Dvor estate, but on its surroundings and the activities that are today most common there—walking, jogging and relaxing in nature. Local residents use the area mainly for leisure activities, and the authors of the project have called their “usual” route the Račji krog—the path leads from the park to the Mitnica café, along the avenue to the furthest point of the estate and then back to the city centre under Kalvarija hill. Based on use and observation, the intervention is designed in a holistic and original way according to the activities (relaxing in nature, sports, socialising) and the main routes of passers-by. While the*

### JURY'S FEEDBACK

authors have created a new route that contributes to the reactivation of the unused micro-locations around the Račji dvor, the character of the three areas is supported by the imaginative and playful design of the activities, the usable objects, and the colour scheme.

The jury proposes to reduce the intervention criteria in accordance with the financial and implementation constraints—to define the exact position and to realise one to a maximum of two objects in each area.

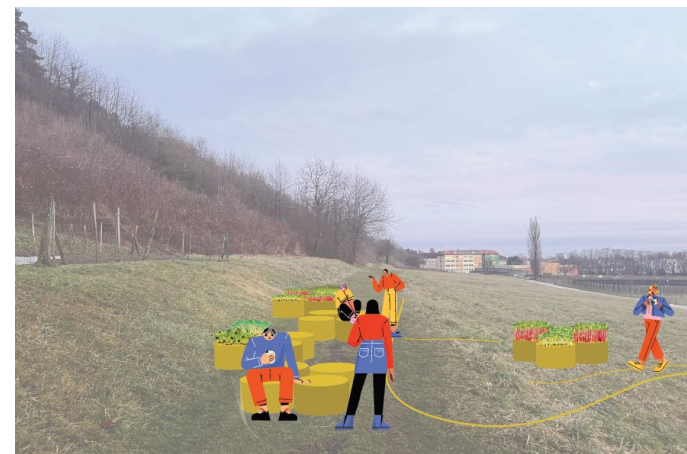
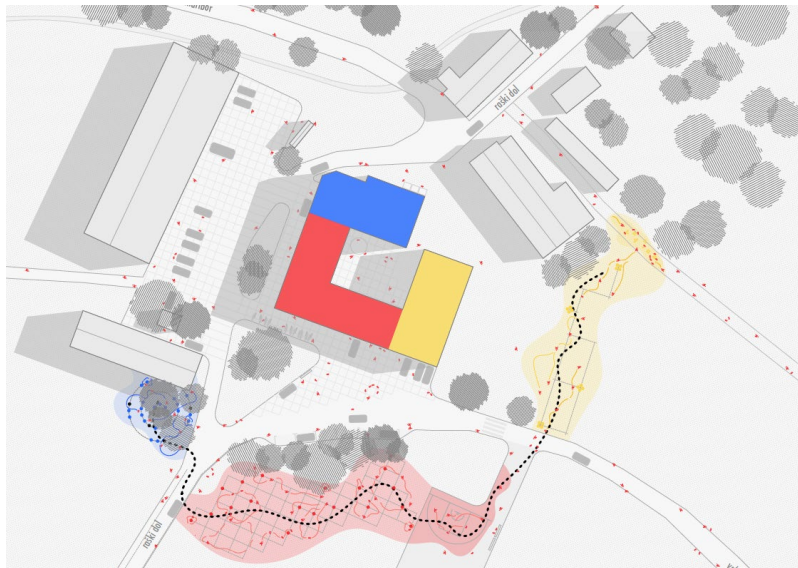

Matic Kašnik

**SPECIAL MENTION**

The installation *Visible Silence* reimagines the abandoned Račji dvor as a sentient being, drawing on Juhani Pallasmaa's critique of vision-centric architecture. The author perceives the building as a living organism, with decaying walls that feel, breathe, and remember. Set in the deteriorated core of the structure, the installation uses projected eyes that respond to environmental sounds—wind, birds, rain, footsteps—captured through audio and video during site visits. This sensory interaction encourages viewers to engage with space not only visually but also emotionally and physically. By turning silence into a perceptible experience, the project highlights the atmospheric richness of Račji dvor and challenges traditional spatial perception. The selected location, shielded yet raw, enhances the feeling of intimacy with the building's layered history. In doing so, the viewer becomes an active medium between the space and its environment, revealing a silent narrative still present in the ruins.



## TIC TAC TOE

Bor Kračun-Pižmoht & Miha Kramberger & Živa Miklavčič

### SPECIAL MENTION

The proposal explores the abstraction of spatial archetypes from Wagner's Hut, using 1:1 scale installations to reinterpret its architectural essence. Inspired by Gottfried Semper's theory of four fundamental architectural elements, the authors focus not on physical components but on the intellectual process of abstraction. Three key vernacular elements are highlighted: the thatched roof, black kitchen, and clay stove—each deeply rooted in Slovenian rural tradition and social history. These installations are arranged in a 15 x 15m grid near Račji dvor, with supplementary information boards offering context without a direct link to the structures. By relocating these symbolic elements into an open and accessible space, the project transforms a historically closed site into a dynamic open-air museum. This spatial fragmentation and recontextualization aim to engage visitors more effectively and convey the cultural narratives embedded in these archetypal forms.

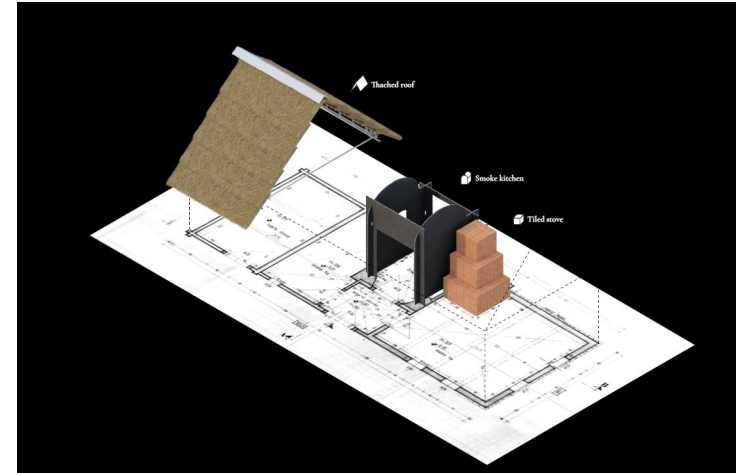

**SPECIAL MENTION**

This multidisciplinary project revitalizes Račji dvor by blending architecture, art, and ecology. A video mapping installation on the manor's facade combines stylized architectural history with scientific illustrations of local biodiversity—frogs, bees, bats, and more—accompanied by ambient and animal sounds. Porcelain sculptures, designed as shelters for these species, integrate classical architectural elements from the manor (windows, portals) and serve both aesthetic and functional roles. These include small ponds for amphibians, bat houses, and wild bee habitats, crafted through hand modeling and 3D printing. In the surrounding garden, twelve grapevines will be planted, each circled by glass sculptures symbolizing wine, water, air, and light. The project visually enriches the space while enabling cohabitation of wildlife and humans. It includes a biodiversity tracking model that estimates species populations and their future growth, promoting education and ecological awareness. Račji dvor thus becomes a living, evolving space—where culture, nature, and community coexist harmoniously.

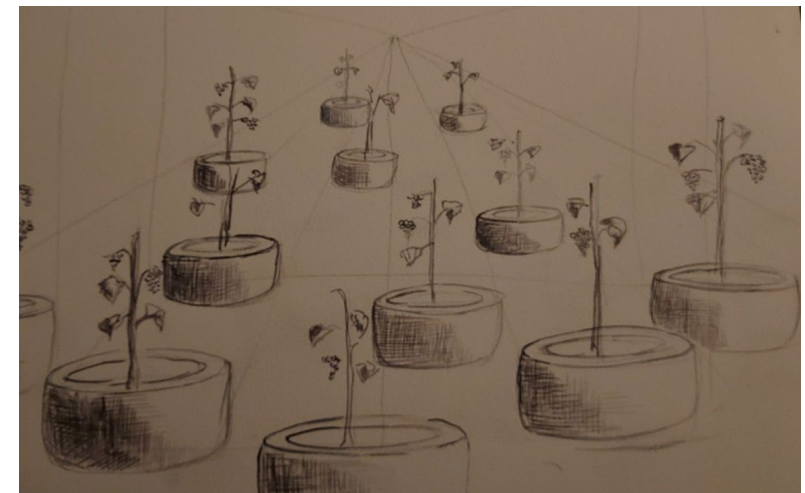
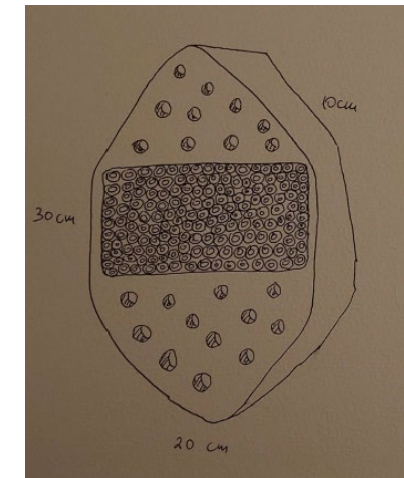
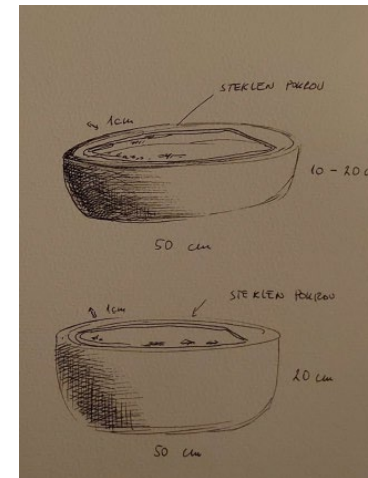



### **Maribor Workshop Team**

Simona Vidmar Čelik, UGM  
Živa Kleindienst, UGM  
Barbara Beškovnik, UGM  
Jure Kirbiš, UGM

### **Experts**

Stojan Skalicky, Arhisol  
Tina Rudolf, Arhisol  
Suzana Vešligaj, Institute for the Protection of Cultural Heritage – Maribor  
Jurij Kobe, ATELIERarhitekti  
Maruša Zorec, Faculty of Architecture, University of Ljubljana  
David Mišič, Styria Arhitektura  
Rok Žnidaršič, Faculty of Architecture, University of Ljubljana, Medprostor  
Jerneja Fischer Knap, Medprostor  
Gašper Medvešek, Faculty of Architecture, University of Ljubljana  
Polonca Lovšin, Faculty of Education, University of Primorska

### **reCITYing Partners**

Nicola Valentino Canessa, UniGE-DAD, Genova  
Giovanna Tagliasco, UniGE-DAD, Genova  
Stella Femke Rigo, UniGe-DAD, Genova  
Jörg Schröder, LUH, Hannover  
Federica Scaffidi, LUH, Hannover  
Laura Guimarães, IAAC, Barcelona  
Ana Galego, IAAC, Barcelona  
Elodie Nourrigat, Champ Libre, Montpellier

Event and location photos by Janez Klenovšek  
All other visual material: courtesy of the authors.